

CUTTING PARTS FOR AGRICULTURAL EQUIPMENT.

INCLUDES: COMBINES • DISC MOWERS • DRAPER HEADERS
MOWERS • MOWER-CONDITIONERS • WINDROWERS
ALL-MAKES • KITS • AND MORE



Always **Be Ready** and Stay Connected With

My Shed™

and **My Shed Mobile App, 2.1.**



Google Play™
for Android™



Apple® Store
for iPhone®



Genuine Case IH Parts: Designed for the Perfect Fit.

The **Partstore** has everything you need to keep your equipment up and running. Now you can easily store your machine models to access parts with **My Shed** and **My Shed Mobile App, 2.1.** My Shed offers:

- **Machine Management:** Enter serial number, hours and notes
- **Parts Manuals:** Access assembly diagrams and create part pick lists
- **24/7 Dealer Connection:** Email part pick lists to a dealer
- **Toolboxes:** Oil/fluid selector and battery finder
- **Machine Info:** Product alerts and videos

Visit partstore.caseih.com today.



CUTTING PARTS FOR TODAY'S DEMANDING APPLICATIONS

Case IH Original Equipment Cutting Parts are designed and manufactured for the finest agricultural harvesting equipment available today. Whether for the Case IH Mower, Mower-Conditioner, Windrower or Combine Header, we've designed knife sections and knife assemblies to go the distance and meet today's demanding cutting applications.

DISC MOWER KNIVES

6 – 12 Blades, Kits

MOWER-COCONDITIONERS

14 – 21 Knife Assemblies, Kits

HAY MACHINES

22 – 29 Knife Assemblies, Kits

WINDROWERS

30 – 39 Knife Assemblies, Kits

COMBINES

40 – 49 Knife Assemblies, Kits

HARDWARE/REPLACEMENT PARTS

50 – 57 Kits, Knife Sections, Knife Clips, Rivets, Bolts

SHAPES CHARTS

58 – 62 Knife Sections

INDEX

63 – 66



EXPLANATION OF ABBREVIATIONS

Abbreviation	Description
REG	Regular Thickness – 14 Gauge Material
HVY	Heavy Thickness – 12 Gauge Material
XHVY	Extra-Heavy Thickness – 11 Gauge Material
SS	Sta-Sharp™ Serration Profile – see page 5
SSS	Super Sta-Sharp™ Serration Profile – see page 5
BL	Black Knife Section Finish
PL	Plated Knife Section Finish
SM	Smooth Knife Section

Abbreviation	Description
US	Under-Serrated Knife Section
TS	Top-Serrated Knife Section
HDLS	Headless Knife Assembly
LH	Left-Hand Side
RH	Right-Hand Side
EXT	Extension
DBL	Double Point Section – 1-1/2" Cut
	Original Factory-Equipped Assembly



CASE IH ORIGINAL EQUIPMENT CUTTING PARTS

Case IH Knife Sections

Tough, Break Resistant Material

All Case IH Knife Sections are manufactured from C1080 – a tough, high carbon material that conforms to ANSI Standards. The cutting edge is induction hardened and tempered to Rockwell C 49-54 for maximum wear resistance. The center of the section remains a more ductile Rockwell C 25 rating to resist breakage. Serrations are coined (formed with the knife in a single process) for maximum consistency and are perpendicular to the center line for improved self-sharpening and cleaning action.

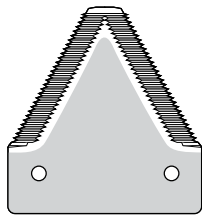

Knife edge is heat treated to RC 49–54 for long life.

Knife body (shaded area) is heat treated to RC 25 for break resistance.

Three Knife Styles for a Wide Range of Applications

Smooth for light grasses and special applications. Can be resharpened as needed. Available in black or chrome finishes.

Under-serrated for general cutting applications. Can be resharpened as needed. Aggressive serrations grab and hold the stem of the crop. Available in black or chrome finishes.

Top-serrated the self-sharpening knife section for combine and most hay cutting applications. Unique design enables these sections to self-sharpen in the field while the machine is operating, reducing downtime. Outlasts conventional knife sections four to one. Case IH Top-serrated knives come in three versions — Standard, STA-SHARP™ and SUPER STA-SHARP™ knives. Top-serrated knives are available in three options – 13, 9 and 7 serrations per inch. STA-SHARP Knives are recommended for general cutting applications. SUPER STA-SHARP knives, with their more aggressive serrations, are ideal for larger, dry stem crops, such as alfalfa, soy beans and cereal grains.



Smooth

Under-serrated

Top-serrated

Case IH Knife Assemblies

Case IH Knife Assemblies are available in an easy-to-maintain bolted version, or the traditional riveted version. Knifebacks are made of high carbon material with a fine grain structure for optimum tensile strength. To guard against premature wear and loose sections, fastener holes are drilled, not punched, leaving a straight hole with no breakout.

Split Knife Assemblies and Segments are available to provide easier shipping and handling from warehouse to dealership to field. The lengths of the segments allow shipments to be made on most popular courier services, speeding up the replacement of knife assemblies that require repair. Split Kits are available for use as replacement splices or repair kits.



Drilled holes are smooth and straight, holding the rivet securely in place.



Punched holes flare out at the bottom, allowing the rivet to rock its way loose.

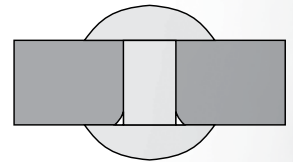
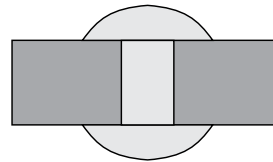

DISC MOWER KNIVES



DISC MOWER KNIVES

- 7** WE OWN THE CUTTING EDGE
- 8** ROTARY DISC MOWER BLADE SELECTION
- 9 – 10** PRODUCT SUPPORT KITS/KNIFE KITS
- 11 – 12** DISC MOWER KNIVES
- 12** OEM CROSS REFERENCE

WE OWN THE CUTTING EDGE

Case IH Mower Knives are superb quality Disc Mower Knives. They boast a number of design features that help them cut smoother, last longer and operate more safely than other knives. Furthermore, each and every production lot is subjected to a rigorous battery of tests to ensure performance standards are met. Each knife bears a stamped Traceable Sequential Lot Number, a unique number that permits tracing the knife back through all of its manufacturing processes.

Manufactured for Maximum Performance

From raw material specification to the last production process, extra care has been taken to assure optimum performance and durability.

- The cutting edge is milled, not rolled, for improved sharpness. The milled edge does not extend past the bolt holes, for increased strength.
- The new, radial-twist design improves lifting action for a smoother cut.
- Disc Knives are austempered for better impact absorption.
- Knives are available in 3, 4 or 5 mm thicknesses with bevel-up, bevel-down or bevel-opposite knife styles.

Traceable Sequential Numbering System Confirms Our Commitment to Do It Right

Every production lot is tested against ISO specifications, then the manufacturing and testing processes are verified by stamping a traceable sequential number on each knife. In addition, tests are performed to satisfy standards set by Case IH – standards that exceed ISO requirements.

- Incoming material is inspected, then tagged for traceability.
- Bend tests are performed to guard against cracking.
- Impact tests are used to check structural integrity.
- Cross section analysis assures optimum metallurgical grain structure.



Our Disc Mower Knives are manufactured in three thicknesses for light, medium and heavy-duty applications.



The new radial-twist design extends down and across the central area of the blade for better lifting action. For more information on rotary disc mower knives, refer to PM-13728.



Cross sections are examined under a microscope for proper grain pattern.



Bend tests are performed on each production lot to determine if cracks are present.



Impact tests check the knives' ability to flex and absorb shock and not shatter into pieces should they hit obstructions.

DISC MOWER KNIVES

ROTARY DISC MOWER BLADE SELECTION

7° TWIST KNIVES

The 7° twist knives are recommended for abrasive soil and rocky crop cutting conditions. These knives function well in a wide range of field and cutting conditions.



PART NUMBER	DESCRIPTION/TYPE PITCH/ROTATION
9847683	Knife – 7° Twist CW
9847684	Knife – 7° Twist CCW

14° TWIST KNIVES (STANDARD EQUIPMENT) & 14° TWIST SERRATED KNIVES

The 14° twist knives are recommended for most crop conditions. The greater twist angle enables the knife's cutting edge to cut closer to the ground and provide more lifting action to move the crop over the cutter bar into the conditioner, producing a cleaner cut. The greater twist angle in these knives makes them more susceptible to rock damage.



SERRATED

PART NUMBER	DESCRIPTION/TYPE PITCH/ROTATION
86621872	Knife – 14° Twist CW
86621873	Knife – 14° Twist CCW
87029587	Knife – 14° Twist OS CW
87029588	Knife – 14° Twist OS CCW

18° KNIVES

The 18° twist knives are standard on RD163 and RD193 self-propelled windrower heads. The 18° twist provides for a close cut and high lift for superior material flow.

PART NUMBER	DESCRIPTION/TYPE PITCH/ROTATION
84271203	Knife – 18° Twist CW
84271205	Knife – 18° Twist CCW

7° KNIVES

The 7° twist knives are available for the RD163 and RD193 self-propelled windrower heads. These knives function well in a variety of crop conditions and are less susceptible to rock damage.

PART NUMBER	DESCRIPTION/TYPE PITCH/ROTATION
84343225	Knife – 7° Twist CW
84343226	Knife – 7° Twist CCW

“V” KNIVES

The “V” knives are recommended for operation in rocky conditions where excessive knife bending is a concern. This style knife has greater resistance to bending when coming in contact with a foreign object. The cutting quality of this knife is not as good compared to the twisted knives.



STANDARD



“V” FOR ROCKY CONDITIONS

PART NUMBER	DESCRIPTION/TYPE PITCH/ROTATION
86532078	Knife – “V” Rock Blade



PRODUCT SUPPORT KITS/KNIFE KITS

DISC MOWER KNIFE WITH HARDWARE (CARDED)

KITS

APPLICATION: MDX71, MDX81, MDX91, Rotary Disc Mower MY 2005 and Later



PART NO. 87298449



PART NO. 87298453

PART NUMBER	DESCRIPTION/TYPE PITCH/ROTATION
87298453	7° Twist CW
87298452	7° Twist CCW
87298451	14° Twist CW
87298450	14° Twist CCW
87298449	"V" Rock Blade



PART NO. 87298584

COMPLETE KIT OF DISC MOWER KNIVES & HARDWARE

KITS

- Complete set of knives and attaching hardware
- OE knives and hardware
- 7°, 14°, 14° OS (serrated) and "V" Rock blade kits
- One box – one part number – one price

PART NUMBER	TWIST	ROTATION	NUMBER OF KNIVES
APPLICATION: MDX71			
87298584	7°	Both	4 CCW and 6 CW
87298585	14°	Both	4 CCW and 6 CW
87298586	"V" Rock Blade	–	10 "V" Blades
APPLICATION: MDX81			
87298590	7°	Both	6 CCW and 6 CW
87298591	14°	Both	6 CCW and 6 CW
87298592	"V" Rock Blade	–	12 "V" Rock Knives
APPLICATION: MDX91			
87298587	7°	Both	6 CCW and 8 CW
87298588	14°	Both	6 CCW and 8 CW
87298589	"V" Rock Blade	–	14 "V" Rock blades
APPLICATION: DCX101			
87298597	7°	Both	8 CCW and 8 CW
87298593	14°	Both	8 CCW and 8 CW
87298601	"V" Rock Blade	–	16 "V" Blades
APPLICATION: DCX131, RDX131, RD132			
87298598	7°	Both	10 CCW and 10 CW
87298594	14°	Both	10 CCW and 10 CW
87298602	"V" Rock Blade	–	20 "V" Rock Knives
APPLICATION: DCX161, DCX162, RDX161, RD162			
87298599	7°	Both	12 CCW and 12 CW
87298595	14°	Both	12 CCW and 12 CW
87298605	14° OS (Serrated)	Both	12 CCW and 12 CW
87298603	"V" Rock Blade	–	24 "V" Rock Knives
APPLICATION: RDX181			
87298600	7°	Both	14 CCW and 14 CW
87298596	14°	Both	14 CCW and 14 CW
87298606	14° OS (Serrated)	Both	14 CCW and 14 CW
87298604	"V" Rock Blade	–	28 "V" Rock Blades

DISC MOWER KNIVES

MOWER-CONDITIONERS

HAY MACHINES

WINDROWERS

COMBINES

HARDWARE/PARTS

SHAPES CHARTS

DISC MOWER KNIVES

PRODUCT SUPPORT KITS/KNIFE KITS

DISC MOWER KNIFE WITH HARDWARE IN HANDY SERVICE PACKS



APPLICATION: Disc Mowers: DCX91, DCX101, DCX131, DCX132, DCX161 with lifters

WINDROWER HEADS: RDX161, RDX162, RDX181 with lifters

PART NUMBER	DESCRIPTION/TYPE PITCH/ROTATION
87298470	7° Twist CW
87298471	7° Twist CCW
87298468	14° Twist CW
87298469	14° Twist CCW
87298466	14° OS (Serrated) CW
87298467	14° OS (Serrated) CCW
87298472	"V" Rock Blade

DISC MOWER KNIFE WITH HARDWARE KITS



- A** Disc Mower Knife – 14° Twist
PART NO. 87298468
- B** Disc Mower Knife – 14° Twist Serrated
PART NO. 87298467
- C** Disc Mower Knife – Rock Knife
PART NO. 87298472



DISC MOWER KNIVES

DISC MOWER KNIVES

PART NUMBER	TWIST	ROTATION	EDGE	LENGTH (MM)	WIDTH (MM)	LENGTH (TIP TO HOLE CENTER)	BOLT HOLE DIA. (MM)
274230	Straight	—	Smooth	93	41	75	18.5
853638	Straight	—	Smooth	107	47	87	18.25
853639	Straight	—	Smooth	116	45	95	18.25
84375859	Rock	—	Smooth	116	50	93	22.75
86532078	Rock	—	Smooth	110	50	87	22.75
766727	7°	CW	Smooth	96	47	76	16.5
766726	7°	CCW	Smooth	96	47	76	16.5
84343225	7°	CCW	Smooth	116	50	93	22.6
84343226	7°	CW	Smooth	116	50	93	22.6
9847683	7°	CW	Smooth	110	50	87	22.6
9847684	7°	CCW	Smooth	110	50	87	22.6
853819	7°	CW	Smooth	110	47	87	18.25
86837561	7°	CCW	Smooth	110	47	87	18.25
785608	8°	CCW	Smooth	116	45	95	18.25
785609	8°	CW	Smooth	116	45	95	18.25
784221	10°	CW	Smooth	120	47	100	18.5
784220	10°	CCW	Smooth	120	47	100	18.5
274097	10°	CW	Smooth	93	41	75	16.5
274096	10°	CCW	Smooth	93	41	75	16.5
87348087	11°	CW	Smooth	105	47	85	21
87348084	11°	CCW	Smooth	105	47	85	21
84177687	11°	CW	Smooth	105	47	82	21
84177688	11°	CCW	Smooth	105	47	82	21
86625667	11°	CW	Smooth	107	47	87	18.5
86625668	11°	CCW	Smooth	107	47	87	18.5
86625669	11°	CW	Smooth	107	47	87	18.25
86625670	11°	CCW	Smooth	107	47	87	18.25
86625671	11°	CW	Smooth	107	47	87	18.5
86625672	11°	CCW	Smooth	107	47	87	18.5
86625665	11°	CW	Smooth	120	50	100	18.25
86625666	11°	CCW	Smooth	120	50	100	18.25
84255699	14°	CW	Smooth	116	50	93	22.6
84255700	14°	CCW	Smooth	116	50	93	22.6
86621872	14°	CW	Smooth	110	50	87	22.6
86621873	14°	CCW	Smooth	110	50	87	22.6
87029587	14°	CW	Serrated	110	50	87	22.6
87029588	14°	CCW	Serrated	110	50	87	22.6
84425930	18°	CW	Serrated	116	50	93	22.6
84425931	18°	CCW	Serrated	116	50	93	22.6
ZA527330	18°	CW	Smooth	120	50	100	18.25
ZA527331	18°	CCW	Smooth	120	50	100	18.25
84271203	18°	CW	Smooth	116	50	93	22.6
84271205	18°	CCW	Smooth	116	50	93	22.6
86625673	18°	CW	Smooth	107	47	87	18.5
88625674	18°	CCW	Smooth	107	47	87	18.5

DISC MOWER KNIVES

MOWER-CONDITIONERS

HAY MACHINES

WINDROWERS

COMBINES

HARDWARE/PARTS

SHAPES CHARTS

DISC MOWER KNIVES

DISC MOWER KNIVES	INCLUDES BLADES		FOR MACHINES UP TO & INCLUDING
86624751	86621872	86621873	10 discs
86624752	86621872	86621873	16 discs
86626704	86625665	86625666	9 discs
86626705	86625667	86625668	10 discs
86626706	86625669	86625670	10 discs
86626707	86625671	86625672	10 discs
86626708	86625673	86625674	10 discs
87037027	87029587	87029588	16 discs

OEM CROSS REFERENCE

OEM PART NUMBER	CNH PART NUMBER
BUSH HOG 526215	86625665
BUSH HOG 526216	86625666
CASE 1133939R1	274096
CASE 1133940R1	274097
CASE IH 700711857	86625667
CASE IH 700711858	86625668
CASE IH 700712888	86625669
CASE IH 700712889	86625670
CASE IH 700713983	86625671
CASE IH 700713984	86625672
CASE IH 700715575	86625673
CASE IH 700715576	86625674
CASE IH ZA526215	86625665
CASE IH ZA526216	86625666
FELLA 111724	86625666
FELLA 111725	86625665
FELLA 478641	86625665
FELLA 478640	86625666
FELLA 478649	86625666
FELLA 478650	86625665
GEHL 113268	86837561
GEHL 113269	853819
GEHL 125446	784221
GEHL 125447	784220
GEHL 604658	86625666
GEHL 604659	86625665
GEHL 612634	86625668
GEHL 612635	86625667
GEHL 612737	766727
GEHL 612738	766726
GREENLAND 1650 3363	86625668
GREENLAND 1650 3364	86625667
GREENLAND 1650 7793	86625665
GREENLAND 1650 7794	86625666
HESSTON 700711857	86625667
HESSTON 700711858	86625668
HESSTON 700712888	86625669
HESSTON 700712889	86625670
HESSTON 700713983	86625671
HESSTON 700713984	86625672

OEM PART NUMBER	CNH PART NUMBER
HESSTON 700715575	86625673
HESSTON 700715576	86625674
JOHN DEERE CC19332	274096
JOHN DEERE CC19333	274097
JOHN DEERE CC20500	766726
JOHN DEERE CC20501	766727
JOHN DEERE CC21780	784220
JOHN DEERE CC21781	784221
JOHN DEERE CC26780	86625670
JOHN DEERE CC26781	86625669
JOHN DEERE CC44004	784221
JOHN DEERE CC44005	784220
JOHN DEERE CC44006	766727
JOHN DEERE CC44007	766726
JOHN DEERE E80206	86625670
JOHN DEERE E80208	86625669
KUHN 55903210	86837561
KUHN 55903310	853819
KUHN 56150000	274230
KUHN 56151200	274096
KUHN 56151210	766726
KUHN 56151300	274097
KUHN 56151310	766727
KUHN 56451200	784220
KUHN 56451300	784221
LELY 4120114730	86625666
LELY 4120114740	86625665
M-F 37302223M1	86625668
M-F 37302224M1	86625667
M-F 37302225M1	86625666
M-F 37302226M1	86625665
N HOLLAND 86561092	86621873
N HOLLAND 86561093	86621872
NEW IDEA 526215	86625665
NEW IDEA 526216	86625666
PW ZWEEGERS DM155	274096
PW ZWEEGERS DM 160	274097
VICON 90258699	86625666
VICON 90258700	86625665
VICON 90261559	86625667
VICON 90261560	86625668

LIGHTEN UP.

**EXTEND THE WORK DAY—SAFELY—WITH LED LIGHTS
FROM YOUR CASE IH DEALER.**



When you switch to LED, superior visibility isn't the only bright spot. In fact, one LED light can outlive more than 20 HID lights, saving time, money and hassle.

Visit BeRedandReady.com/LED to learn more about the advantages of LED.

MOWER-COCONDITIONERS



MOWER-COCONDITIONERS

- 15** 555 MOWER-COCONDITIONER
- 15** 990 MOWER-COCONDITIONER
- 16** 1190 MOWER-COCONDITIONER
- 16** 1490 & 1590 MOWER-COCONDITIONERS
- 17** 8320 & 8330 MOWER-COCONDITIONERS
- 17** 8340 MOWER-COCONDITIONER
- 17** 8350 MOWER-COCONDITIONER
- 18** ALL MOWERS EXCEPT BALANCE HEAD TYPE
- 18** BALANCE HEAD SERIES MOWERS
- 19** SC412 (8360) & SC414 (8370) MOWER-COCONDITIONERS
- 20** SC414 DLX & SC416 DLX (8380) MOWER-COCONDITIONERS
- 21** SMX 91 MOWER-COCONDITIONER
- 21** HESTON MOWER-COCONDITIONER MODELS PT-10 & 1010

KNIFE ASSEMBLIES – CASE IH

555 MOWER CONDITIONER

Hesston PT-7 (7'), PT-10, 1010 (9')

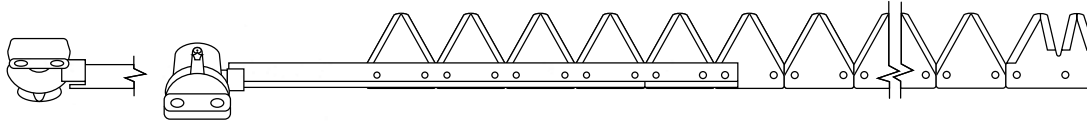

KNIFE ASSEMBLY	AVAILABILITY		PLAT-FORM LENGTH	NUMBER OF KNIFE SECTIONS	KNIFE SECTION	TYPE OF SECTION	FASTENERS				FASTENER LOCKNUT (IF REQ.)	KNIFE CLIPS				HEAD NUMBER
	DEPOT	DIRECT SHIP					KNIFEHEAD		ASSEMBLY			KNIFEHEAD		ASSEMBLY		
							PART NO.	QTY.	PART NO.	QTY.		PART NO.	QTY.	PART NO.	QTY.	
BOLTED																
B92229	—	X	9 ft	37	700705300	XHVY-TS-PL	86517390	11	86507777	65	848083	84389554	1	84389548	8	451948

990 MOWER CONDITIONER

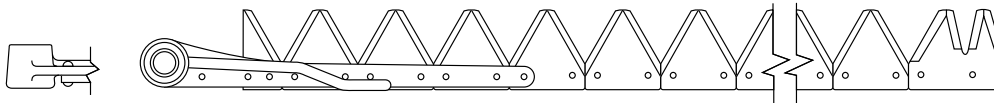

KNIFE ASSEMBLY	AVAILABILITY		PLAT-FORM LENGTH	NUMBER OF KNIFE SECTIONS	KNIFE SECTION	TYPE OF SECTION	FASTENERS				FASTENER LOCKNUT (IF REQ.)	KNIFE CLIPS				HEAD NUMBER
	DEPOT	DIRECT SHIP					KNIFEHEAD		ASSEMBLY			KNIFEHEAD		ASSEMBLY		
							PART NO.	QTY.	PART NO.	QTY.		PART NO.	QTY.	PART NO.	QTY.	
BOLTED																
ZAK540605	—	X	9 ft	35	826722C2	XHVY-US-BL	86507778	10	86507777	65	848083	84389554	1	84389548	8	540607R1
ZAK540605T	—	X	9 ft	35	700705300	XHVY-TS-PL	86507778	10	86507777	65	848083	84389554	1	84389548	8	540607R1
RIVETED																
542816R92	X	—	7 ft	27	826722C2	XHVY-US-BL	9-65474	10	B91969	49	—	611759R1	1	1307280C3	6	540607R1
540605R92	X	X	9 ft	35	826722C2	XHVY-US-BL	1-86511990DS	10	B91969	65	—	611759R1	1	1307280C3	8	540607R1

GENUINE PARTS STORE

www.partstore.caseih.com

MOWER-CONDITIONERS

KNIFE ASSEMBLIES – CASE IH

1190 MOWER CONDITIONER

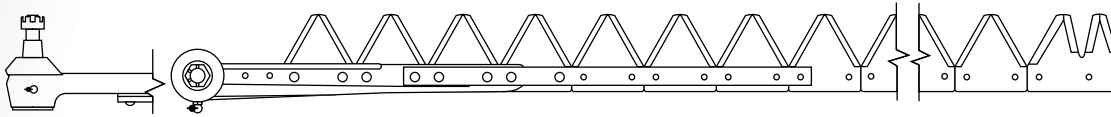

KNIFE ASSEMBLY	AVAILABILITY		PLAT-FORM LENGTH	NUMBER OF KNIFE SECTIONS	KNIFE SECTION	TYPE OF SECTION	FASTENERS				FASTENER LOCKNUT (IF REQ.)	KNIFE CLIPS				HEAD NUMBER
	DEPOT	DIRECT SHIP					KNIFEHEAD		ASSEMBLY			KNIFEHEAD		ASSEMBLY		
							PART NO.	QTY.	PART NO.	QTY.		PART NO.	QTY.	PART NO.	QTY.	
BOLTED																
ZAK101988	—	X	9 ft	32 4	457607R3 823711C3	XHVV-US-PL XHVV-US-PL	B92259 86507779	8 7	86507777	66	848083	84389554	1	84389548	8	824594C91
ZAK101988T	—	X	9 ft	32 4	700705300 823713C3	XHVV-TS-PL XHVV-TS-PL	B92259 86507779	8 7	86507777	66	848083	84389554	1	84389548	8	824594C91
RIVETED																
101987C95	X	—	7 ft	28 4	457607R3 823711C3	XHVV-US-PL XHVV-US-PL	45-418 990325R91 MA133M	4 4 7	B91969	50	—	611759R1	1	1307280C3	6	824594C91
101988C95	X	X	9 ft	32 4	457607R3 823711C3	XHVV-US-PL XHVV-US-PL	45-418 990325R91 MA133M	4 4 7	B91969	59	—	611759R1	1	1307280C3	8	824594C91
1960310C1	X	—	9 ft	32 4	700705300 823713C3	XHVV-TS-PL XHVV-TS-PL	45-418 990325R91 MA133M	4 4 7	B919169	59	—	611759R1	1	1307280C3	8	824594C91

1490 & 1590 MOWER CONDITIONERS

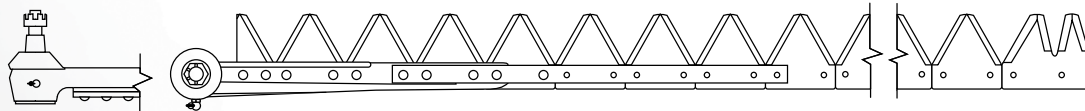

KNIFE ASSEMBLY	AVAILABILITY		PLAT-FORM LENGTH	NUMBER OF KNIFE SECTIONS	KNIFE SECTION	TYPE OF SECTION	FASTENERS				FASTENER LOCKNUT (IF REQ.)	KNIFE CLIPS				HEAD NUMBER
	DEPOT	DIRECT SHIP					KNIFEHEAD		ASSEMBLY			KNIFEHEAD		ASSEMBLY		
							PART NO.	QTY.	PART NO.	QTY.		PART NO.	QTY.	PART NO.	QTY.	
BOLTED																
ZAK502930	—	X	12 ft	44 4	700705300 823713C3	XHVV-TS-PL XHVV-TS-PL	B92259 86507778	10 7	86507777	83	848083	—	1	1307280C3	11	ZA502562
ZAK502931	—	X	14 ft	52 4	700705300 823713C3	XHVV-TS-PL XHVV-TS-PL	B92259 86507778	10 7	86507777	99	848083	—	1	1307280C3	13	ZA502562
RIVETED																
ZA502930	X	—	12 ft	44 4	700705300 823713C3	XHVV-TS-PL XHVV-TS-PL	45-418 990325R91 64691	4 6 7	B91969	83	—	611759R1	1	1307280C3	11	ZA502562

KNIFE ASSEMBLIES – CASE IH

8320 & 8330 7' & 9' MOWER CONDITIONERS

Hesston 1110 & 1120

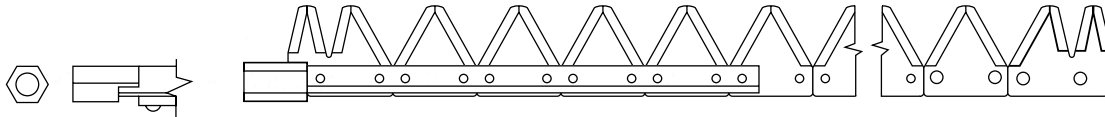

KNIFE ASSEMBLY	AVAILABILITY		PLAT-FORM LENGTH	NUMBER OF KNIFE SECTIONS	KNIFE SECTION	TYPE OF SECTION	FASTENERS				FASTENER LOCKNUT (IF REQ.)	KNIFE CLIPS				HEAD NUMBER
	DEPOT	DIRECT SHIP					KNIFEHEAD		ASSEMBLY			KNIFEHEAD		ASSEMBLY		
							PART NO.	QTY.	PART NO.	QTY.		PART NO.	QTY.	PART NO.	QTY.	
BOLTED																
700712775	X	—	7 ft	27	700705300	XHVV-TS-PL	86507778	6	86507777	50	848083	142984	1	700111204	6	70071325
700709588	X	X	9 ft	35	700705300	XHVV-TS-PL	86517390	11	86507777	64	848083	142984	1	700111204	8	6821078
700711767	X	—	9 ft	35	700705300	XHVV-TS-PL	700706479	4	86507777	66	848083	142984	1	700111204	8	700713251

NOTE: 700709588 is for pre-May 1992 models.
700712775 & 700711767 are for post-May 1992 models.

8340 9' MOWER CONDITIONER

Hesston 1130

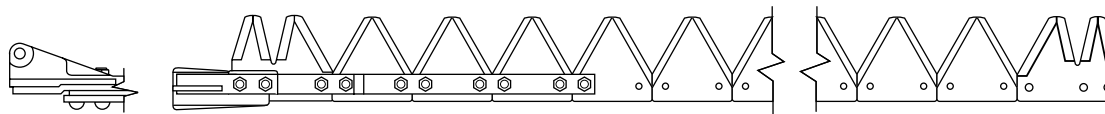

KNIFE ASSEMBLY	AVAILABILITY		PLAT-FORM LENGTH	NUMBER OF KNIFE SECTIONS	KNIFE SECTION	TYPE OF SECTION	FASTENERS				FASTENER LOCKNUT (IF REQ.)	KNIFE CLIPS				HEAD NUMBER		
	DEPOT	DIRECT SHIP					KNIFEHEAD		ASSEMBLY			KNIFEHEAD		ASSEMBLY				
							PART NO.	QTY.	PART NO.	QTY.		PART NO.	QTY.	PART NO.	QTY.			
BOLTED																		
700118673	X	X	9 ft	35	700705300	XHVV-TS-PL	700706479	2	86507778	6	86507777	66	848083	N/A	N/A	700109725	9	700111003
							1979166C1	2										

8350 12' MOWER CONDITIONER

Hesston 1150

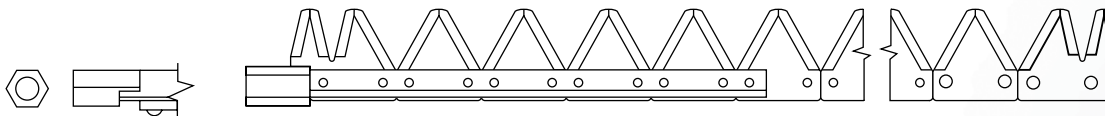

KNIFE ASSEMBLY	AVAILABILITY		PLAT-FORM LENGTH	NUMBER OF KNIFE SECTIONS	KNIFE SECTION	TYPE OF SECTION	FASTENERS				FASTENER LOCKNUT (IF REQ.)	KNIFE CLIPS				HEAD NUMBER
	DEPOT	DIRECT SHIP					KNIFEHEAD		ASSEMBLY			KNIFEHEAD		ASSEMBLY		
							PART NO.	QTY.	PART NO.	QTY.		PART NO.	QTY.	PART NO.	QTY.	
BOLTED																
700709583	X	X	12 ft	46	700705300	XHVV-TS-PL	86517390	11	86507777	85	848083	142984	1	700109725	11	6821078

MOWER-CONDITIONERS

KNIFE ASSEMBLIES – CASE IH

ALL MOWERS EXCEPT BALANCED HEAD TYPE

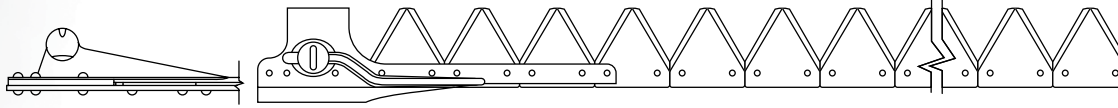

KNIFE ASSEMBLY	AVAILABILITY		PLATFORM LENGTH	NUMBER OF KNIFE SECTIONS	KNIFE SECTION	TYPE OF SECTION	FASTENERS				FASTENER LOCKNUT (IF REQ.)	KNIFE CLIPS				HEAD NUMBER
	DEPOT	DIRECT SHIP					KNIFEHEAD		ASSEMBLY			KNIFEHEAD		ASSEMBLY		
							PART NO.	QTY.	PART NO.	QTY.		PART NO.	QTY.	PART NO.	QTY.	
BOLTED																
ZAK1958203	—	X	7 ft	28	826724C2	XHVY-SM-BL	86507779	10	86507777	49	848083	84389554	1	84389548	6	MA999
ZAK1958207	—	X	7 ft	28	826722C2	XHVY-US-BL	86507778	10	86507777	49	848083	84389554	1	84389548	6	MA999
ZAK463294	—	X	9 ft	36	826722C2	XHVY-US-BL	86507778	10	86507777	65	848083	84389554	1	84389548	8	MA999
RIVETED																
1958205C1	X	—	5 ft	20	826722C2	XHVY-US-BL	MA133M	10	B91969	33	—	611759R1	1	MA812	4	MA999
1958207C1	X	X	7 ft	28	826722C2	XHVY-US-BL	MA133M	10	B91969	49	—	611759R1	1	MA812	6	MA999
1958203C1	X	—	7 ft	28	826724C2	XHVY-SM-BL	MA133M	10	B91969	49	—	611759R1	1	MA812	6	MA999

BALANCED HEAD SERIES MOWERS

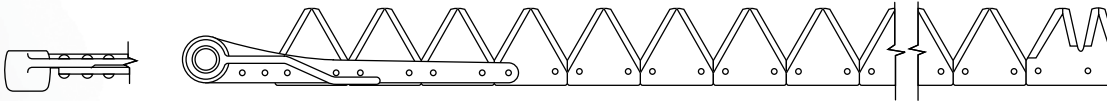

KNIFE ASSEMBLY	AVAILABILITY		PLATFORM LENGTH	NUMBER OF KNIFE SECTIONS	KNIFE SECTION	TYPE OF SECTION	FASTENERS				FASTENER LOCKNUT (IF REQ.)	KNIFE CLIPS				HEAD NUMBER
	DEPOT	DEPOT SHIP					KNIFEHEAD		ASSEMBLY			KNIFEHEAD		ASSEMBLY		
							PART NO.	QTY.	PART NO.	QTY.		PART NO.	QTY.	PART NO.	QTY.	
BOLTED																
ZAK462381	—	X	7 ft	27	826724C2	XHVY-SM-BL	86507779	9	86507777	49	848083	84389554	1	84389548	6	56692C91
ZAK462380	—	X	7 ft	27	826722C2	XHVY-US-BL	86507779	9	86507777	49	848083	84389554	1	84389548	6	56692C91
ZAK128129	—	X	7 ft	27	826720C3	XHVY-TS-BL	86507779	9	86507777	49	848083	84389554	1	84389548	6	56692C91
ZAK463159T	—	X	9 ft	35	—	REG-TS-BL	86507779	9	86507777	65	848083	84389554	1	84389548	8	56692C91
ZAK463159	—	X	9 ft	35	826722C2	XHVY-US-BL	86507779	9	86507777	65	848083	84389554	1	84389548	8	56692C91
ZAK1281291	—	X	9 ft	35	826720C3	XHVY-TS-BL	86507779	9	86507777	65	848083	84389554	1	84389548	8	56692C91
B95034	—	X	9 ft	35	112074A1	XHVY-SS-BL	86507779	9	86507777	65	848083	84389554	1	84389548	5	56692C91
RIVETED																
463408R93	X	—	5 ft	19	826722C2	XHVY-US-BL	86511990	9	B91969	33	—	611759R1	1	MA812	4	56692C91
462381R93	X	—	7 ft	27	826724C2	XHVY-SM-BL	86511990	9	B91969	49	—	611759R1	1	MA812	6	56692C91
462380R93	X	X	7 ft	27	826722C2	XHVY-US-BL	86511990	9	B91969	49	—	611759R1	1	MA812	6	56692C91
458968R93	X	—	7 ft	27	67630	REG-US-BL	86511990	9	B91969	49	—	611759R1	1	MA812	6	56692C91
467749R92	X	—	7 ft	27	457607R3	XHVY-US-PL	86511990	9	B91969	49	—	611759R1	1	MA812	6	56692C91
463182R93	X	X	9 ft	35	826724C2	XHVY-SM-BL	86511990	9	B91969	65	—	611759R1	1	MA812	8	56692C91
463159R93	X	X	9 ft	35	826722C2	XHVY-US-BL	86511990	9	B91969	65	—	611759R1	1	MA812	8	56692C91
1281291C92	X	X	9 ft	35	826720C3	XHVY-TS-BL	86511990	9	B91969	65	—	611759R1	1	MA812	8	56692C91

KNIFE ASSEMBLIES – CASE IH

SC412 (8360) 12' & SC414 (8370) 14' CENTER PIVOT MOWER CONDITIONERS

Hesston 1260 & 1265 (1160)

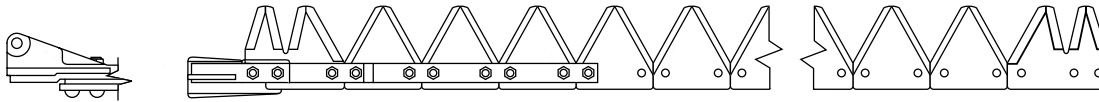

KNIFE ASSEMBLY	AVAILABILITY		PLAT-FORM LENGTH	NUMBER OF KNIFE SECTIONS	KNIFE SECTION	TYPE OF SECTION	FASTENERS				FASTENER LOCKNUT (IF REQ.)	KNIFE CLIPS				HEAD NUMBER		
	DEPOT	DIRECT SHIP					KNIFEHEAD		ASSEMBLY			KNIFEHEAD		ASSEMBLY				
							PART NO.	QTY.	PART NO.	QTY.		PART NO.	QTY.	PART NO.	QTY.			
BOLTED																		
700709622	X	X	12 ft	46	700705300	XHVY-TS-PL	86507778	6	700706479	2	86507777	88	848083	N/A	N/A	700109725	13	700111003
							1979166C1	2								700134757*	20	
ZAK7709622	—	X	12 ft	46	700705300	XHVY-TS-PL	86507778	6	700706479	4	86507777	87	848083	N/A	N/A	700109725	13	HDLS
							700706479	2								700134757*	20	
700709623	X	X	14 ft	54	700705300	XHVY-TS-PL	86507778	6	700706479	2	86507777	104	848083	N/A	N/A	700109725	15	700111003
							1979166C1	2								700134757*	24	
ZAK7709623C	—	X	14 ft	54	700705300	XHVY-TS-PL	86507778	6	700706479	4	86507777	103	848083	N/A	N/A	700109725	15	HDLS
							700706479	2								700134757*	24	

*New Knife Clips for SC412 & SC414 only.



MOWER-CONDITIONERS

KNIFE ASSEMBLIES – CASE IH

SC414 DLX 14' & SC416 DLX (8380) 16' CENTER PIVOT MOWER CONDITIONERS

Hesston 1270, 1275 (1170)

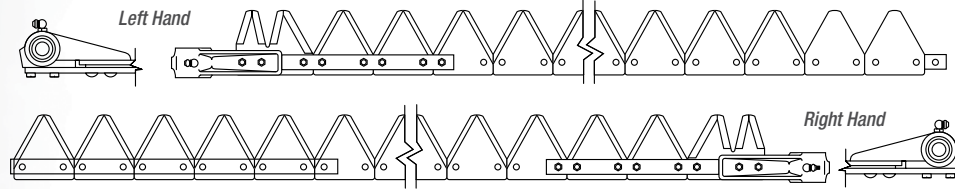

KNIFE ASSEMBLY	AVAILABILITY		PLAT-FORM LENGTH	NUMBER OF KNIFE SECTIONS	KNIFE SECTION	TYPE OF SECTION	FASTENERS				FASTENER LOCKNUT (IF REQ.)	KNIFE CLIPS				HEAD NUMBER		
	DEPOT	DIRECT SHIP					KNIFEHEAD		ASSEMBLY			PART NO.	QTY.	KNIFEHEAD			ASSEMBLY	
							PART NO.	QTY.	PART NO.	QTY.				PART NO.	QTY.		PART NO.	QTY.
BOLTED																		
700715165 7 ft (LH)	X	X	14 ft	25 2	700705300 51200279	XHVV-TS-PL SAWTOOTH	86507778 700706479	6 2	86507777 700715160	45 5	848083	—	—	700109725 700134758* 700109725*	6 10 1	700114594		
700715166 7 ft (RH)	X	X	14 ft	25 3	700705300 51200281	XHVV-TS-PL OVERLAP	86507778 700706479	6 2	86507777 700715160 86577390	40 6 5	848083	—	—	700109725 700134757*	6 11	700114594		
B95021 7 ft (LH)	—	X	14 ft	25 2	191256A1 51200279	XHVV-SS-PL SAWTOOTH	86507778 700706479	6 2	86507777 700715160	45 5	848083	—	—	700109725 700134758* 700109725*	6 10 1	700114594		
B95022 7 ft (RH)	—	X	14 ft	25 3	191256A1 748210 51200281	XHVV-SS-PL OVERLAP	86507778 700706479	6 2	86507777 700715160 86517390	40 6 5	848083	—	—	700109725 700134757*	6 11	700114594		
700715167 8 ft (LH)	X	X	16 ft	29 2	700705300 51200279	XHVV-TS-PL SAWTOOTH	86507778 700706479	6 2	86507777 700715160	53 5	848083	—	—	700109725 700134758* 700109725*	7 12 1	700114594		
700715168 8 ft (RH)	X	X	16 ft	29 3	700705300 51200281	XHVV-TS-PL OVERLAP	86507778 700706479	6 2	86507777 700715160 86517390	48 6 5	848083	—	—	700109725 700134757*	7 13	700114594		
B95023 8 ft (LH)	—	X	16 ft	29 2	191256A1 51200279	XHVV-SS-PL SAWTOOTH	86507778 700706479	6 2	86507777 700715160	53 5	848083	—	—	700109725 700134758* 700109725*	7 12 1	700114594		
B95024 8 ft (RH)	—	X	16 ft	29 3	191256A1 51200281	XHVV-SS-PL OVERLAP	86507778 700706479	6 2	86507777 700715160 86517390	48 6 5	848083	—	—	700109725 700134757*	7 13	700114594		
B95027 8 ft (LH)	—	X	16 ft	29 2	700705300 51200279	XHVV-TS-PL SAWTOOTH	— —	— —	86507777 700715160	53 5	848083	—	—	700109725 700134758* 700109725*	7 12 1	HDLS		
B95028 8 ft (RH)	—	X	16 ft	29 3	700705300 51200281	XHVV-TS-PL OVERLAP	86507778 700706479	6 2	86507777 700715160 86517390	48 6 5	848083	—	—	700109725 700134757*	7 13	HDLS		

*New Knife Clips for SC414 DLX & SC416 DLX only. 700109725 is a Center Knife Clip for SC414 DLX & SC416 DLX.

KNIFE ASSEMBLIES – CASE IH

SMX 91 MOWER CONDITIONER

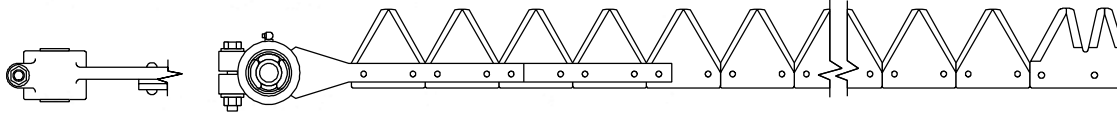

KNIFE ASSEMBLY	AVAILABILITY		PLATFORM LENGTH	NUMBER OF KNIFE SECTIONS	KNIFE SECTION	TYPE OF SECTION	HEAD NUMBER
	DEPOT	DIRECT SHIP					
BOLTED							
86624469	X	X	9 ft	36 1	86615988 86617760	XHVV-TS-BL RH-END-TS-BL	80289488

KNIFE ASSEMBLIES – ALL-MAKES

HESTON MOWER CONDITIONER MODELS PT-10 & 1010

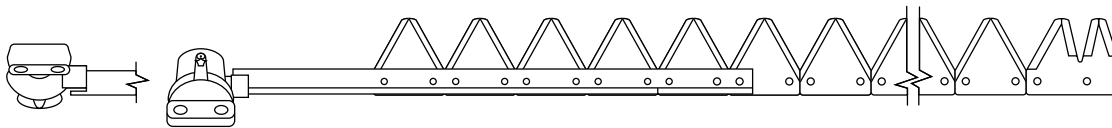

KNIFE ASSEMBLY	AVAILABILITY		REPLACEMENT FOR	PLATFORM LENGTH	NUMBER OF KNIFE SECTIONS	REPLACEMENT KNIFE SECTION	TYPE OF SECTION	WITH KNIFEHEAD OR HEADLESS
	DEPOT	DIRECT SHIP						
BOLTED								
B92229	—	X	6566178	9 ft	37	B92458	REG-TS-CR	With Knifehead



HAY MACHINES



HAY MACHINES

- 23** HDX 121, 141, 161, 181 WINDROWERS
- 24** HDX 121, 122, 141, 142, 161, 162, 181, 182 WINDROWERS
- 25** CUTTING PARTS FOR OTHER BRANDS
- 26 – 28** KITS

KNIFE ASSEMBLIES – CASE IH

HDX 121, 141, 161, 181 WINDROWERS

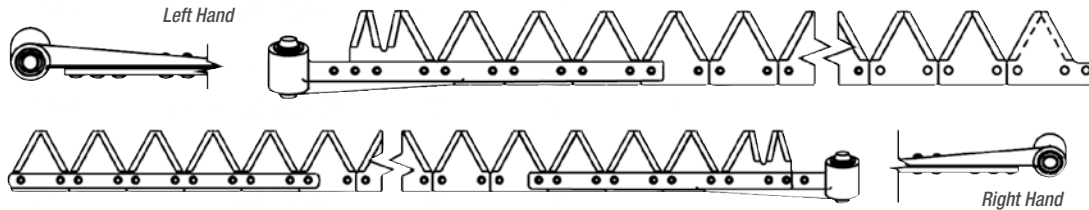

SICKLE LENGTH	PART NUMBER	DEPOT	DIRECT SHIP	SECTION TYPE	FASTENER TYPE	SECTION NUMBER	NUMBER OF SECTIONS	END SECTION NUMBER	KNIFEHEAD PART NUMBER	BUSHING PART NUMBER
6 ft (LH)	86616061	X	X	XH TS BL BK	Bolted	86615988	21	86617759	86617755	76417
6 ft (RH)	86616062	X	X	XH TS BL BK	Bolted	86615988	21	86617760	86617752	76417
6 ft (LH)	86616536	X	—	XH TS PL BK	Bolted	86616527	21	86617759	86617755	76417
6 ft (RH)	86616537	X	—	XH TS PL BK	Bolted	86616527	21	86617760	86617752	76417
6 ft (LH)	86616544	X	—	XH TS PL BK	Bolted	86616527	23	86617759	HDLS	—
6 ft (RH)	86616545	X	—	XH TS PL BK	Bolted	86616527	21	86617760	HDLS	—
6 ft (LH)	86616702	X	—	XH SS BL BK	Bolted	86616691	23	86617759	HDLS	—
6 ft (RH)	86616703	X	—	XH SS BL BK	Bolted	86616691	22	—	HDLS	—
6 ft (LH)	86616718	X	—	XH SS BL BK	Bolted	86616691	21	86617759	86617755	76417
6 ft (RH)	86616719	X	—	XH SS BL BK	Bolted	86616691	21	86617760	86617752	76417
6 ft (LH)	86616710	X	—	XH SS PL BK	Bolted	86616689	23	86617759	HDLS	—
6 ft (RH)	86616711	X	—	XH SS PL BK	Bolted	86616689	22	86617760	HDLS	—
6 ft (LH)	86616726	X	—	XH SS PL BK	Bolted	86616689	23	86617759	86617755	76417
6 ft (RH)	86616727	X	—	XH SS PL BK	Bolted	86616689	22	86617760	86617752	76417
6 ft (LH)	86616616	X	—	XH SSS BL BK	Bolted	86616588	21	86617759	86617755	76417
6 ft (RH)	86616617	X	—	XH SSS BL BK	Bolted	86616588	22	86617760	86617752	76417
6 ft (LH)	86616632	X	—	XH SSS BL BK	Bolted	86616588	23	86617759	HDLS	—
6 ft (RH)	86616633	X	—	XH SSS BL BK	Bolted	86616588	22	86617760	HDLS	—
6 ft (LH)	86616607	X	—	XH SSS PL BK	Bolted	86616591	21	86617759	86617755	76417
6 ft (RH)	86616608	X	—	XH SSS PL BK	Bolted	86616591	22	86617760	86617752	76417
6 ft (LH)	86616624	X	—	XH SSS PL BK	Bolted	86616591	23	86617759	HDLS	—
6 ft (RH)	86616625	X	—	XH SSS PL BK	Bolted	86616591	22	86617760	HDLS	—
7 ft (LH)	86616059	X	X	XH TS BL BK	Bolted	86615988	25	86617759	86617755	76417
7 ft (RH)	86616060	X	X	XH TS BL BK	Bolted	86615988	25	86617760	86617752	76417
7 ft (LH)	86616076	X	X	XH TS BL BK	Bolted	86615988	25	86617759	HDLS	—
7 ft (RH)	86616077	X	X	XH TS BL BK	Bolted	86615988	25	86617760	HDLS	—
7 ft (LH)	86616534	X	X	XH TS PL BK	Bolted	86616527	25	86617759	86617755	76417
7 ft (RH)	86616535	X	X	XH TS PL BK	Bolted	86616527	25	86617760	86617752	76417
7 ft (LH)	86616542	X	X	XH TS PL BK	Bolted	86616527	25	86617759	HDLS	—
7 ft (RH)	86616543	X	X	XH TS PL BK	Bolted	86616527	25	86617760	HDLS	—
7 ft (LH)	86616700	X	—	XH SS BL BK	Bolted	86616691	28	6616591	HDLS	—
7 ft (RH)	86616701	X	—	XH SS BL BK	Bolted	86616691	25	—	HDLS	—
7 ft (LH)	86616716	X	X	XH SS BL BK	Bolted	86616691	25	86617759	86617755	76417
7 ft (RH)	86616717	X	X	XH SS BL BK	Bolted	86616691	25	86617760	86617752	76417
7 ft (LH)	86616708	X	—	XH SS PL BK	Bolted	86616689	25	86617759	HDLS	—
7 ft (RH)	86616709	X	—	XH SS PL BK	Bolted	86616689	25	86617760	HDLS	—
7 ft (LH)	86616724	X	X	XH SS PL BK	Bolted	86616689	25	86617759	86617755	76417
7 ft (RH)	86616725	X	X	XH SS PL BK	Bolted	86616689	25	86617760	86617752	76417
7 ft (LH)	86616614	X	X	XH SSS BL BK	Bolted	86616588	25	86617759	86617755	76417
7 ft (RH)	86616615	X	X	XH SSS BL BK	Bolted	86616588	25	86617760	86617752	76417
7 ft (LH)	86616630	X	X	XH SSS BL BK	Bolted	86616588	25	86617759	HDLS	76417
7 ft (RH)	86616631	X	X	XH SSS BL BK	Bolted	86616588	25	86617760	HDLS	76417
7 ft (LH)	86616605	X	X	XH SSS PL BK	Bolted	86616591	25	86617759	86617755	76417
7 ft (RH)	86616606	X	X	XH SSS PL BK	Bolted	86616591	25	86617760	86617752	76417
7 ft (LH)	86616622	X	X	XH SSS PL BK	Bolted	86616591	25	86617759	HDLS	—
7 ft (RH)	86616623	X	X	XH SSS PL BK	Bolted	86616591	25	86617760	HDLS	—
8 ft (LH)	86616057	X	X	XH TS BL BK	Bolted	86615988	29	86617759	86617755	76417
8 ft (RH)	86616058	X	X	XH TS BL BK	Bolted	86615988	29	86617760	86617752	76417
8 ft (LH)	86616074	X	X	XH TS BL BK	Bolted	86615988	29	86617759	HDLS	—
8 ft (RH)	86616075	X	X	XH TS BL BK	Bolted	86615988	29	86617760	HDLS	—
8 ft (LH)	86616532	X	X	XH TS PL BK	Bolted	86616527	29	86617759	86617759	76417
8 ft (RH)	86616533	X	X	XH TS PL BK	Bolted	86616527	29	86617760	86617752	76417

Original factory-equipped assembly.

DISC MOWER KNIVES

MOWER-CONDITIONERS

HAY MACHINES

WINDROWERS

COMBINES

HARDWARE/PARTS

SHAPES CHARTS

HAY MACHINES

KNIFE ASSEMBLIES – CASE IH

HDX 121, 122, 141, 142, 161, 162, 181, 182 WINDROWERS

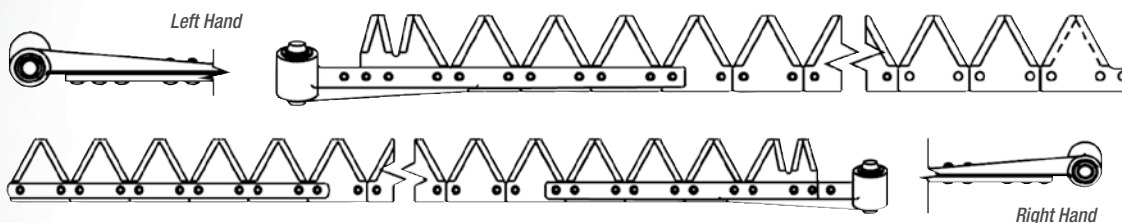

SICKLE LENGTH	PART NUMBER	DEPOT	DIRECT SHIP	SECTION TYPE	FASTENER TYPE	SECTION NUMBER	NUMBER OF SECTIONS	END SECTION NUMBER	KNIFEHEAD PART NUMBER	BUSHING PART NUMBER
8 ft (LH)	86616540	X	X	XH TS PL BK	Bolted	86616527	29	86617759	HDLS	—
8 ft (RH)	86616541	X	X	XH TS PL BK	Bolted	86616527	29	86617760	HDLS	—
8 ft (LH)	86616698	X	—	XH SS BL BK	Bolted	86616691	29	86617759	HDLS	—
8 ft (RH)	86616699	X	—	XH SS BL BK	Bolted	86616691	29	86617760	HDLS	—
8 ft (LH)	86616714	X	X	XH SS BL BK	Bolted	86616691	29	86617759	86617755	76417
8 ft (RH)	86616715	X	X	XH SS BL BK	Bolted	86616691	29	86617760	86617752	76417
8 ft (LH)	86616706	X	—	XH SS PL BK	Bolted	86616689	29	86617759	HDLS	—
8 ft (RH)	86616707	X	—	XH SS PL BK	Bolted	86616689	29	86617760	HDLS	—
8 ft (LH)	86616722	X	X	XH SS PL BK	Bolted	86616689	29	86617759	86617755	76417
8 ft (RH)	86616723	X	X	XH SS PL BK	Bolted	86616689	29	86617760	86617752	76417
8 ft (LH)	86616612	X	X	XH SSS BL BK	Bolted	86616588	29	86617759	86617755	76417
8 ft (RH)	86616613	X	X	XH SSS BL BK	Bolted	86616588	29	86617760	86617752	76417
8 ft (LH)	86616628	X	X	XH SSS BL BK	Bolted	86616588	29	86617759	HDLS	—
8 ft (RH)	86616629	X	X	XH SSS BL BK	Bolted	86616588	29	86617760	HDLS	—
8 ft (LH)	86616603	X	X	XH SSS PL BK	Bolted	86616591	29	86617759	86617755	76417
8 ft (RH)	86616604	X	X	XH SSS PL BK	Bolted	86616591	29	86617760	86617752	76417
8 ft (LH)	86616620	X	X	XH SSS PL BK	Bolted	86616591	29	86617759	HDLS	—
8 ft (RH)	86616621	X	X	XH SSS PL BK	Bolted	86616591	29	86617760	HDLS	—
9 ft (LH)	86616055	X	X	XH TS BL BK	Bolted	86615988	33	86617759	86617755	76417
9 ft (RH)	86616056	X	X	XH TS BL BK	Bolted	86615988	33	86617760	86617752	76417
9 ft (LH)	86616072	X	X	XH TS BL BK	Bolted	86615988	33	86617759	HDLS	—
9 ft (RH)	86616073	X	X	XH TS BL BK	Bolted	86615988	33	86617760	HDLS	—
9 ft (LH)	86616530	X	X	XH TS PL BK	Bolted	86616527	33	86617759	86617755	76417
9 ft (RH)	86616531	X	X	XH TS PL BK	Bolted	86616527	33	86617760	86617752	76417
9 ft (LH)	86616534	X	X	XH TS PL BK	Bolted	86616527	31	86615985	86617755	76417
9 ft (RH)	86616535	X	X	XH TS PL BK	Bolted	86616527	30	—	86617752	76417
9 ft (LH)	86616538	X	X	XH TS PL BK	Bolted	86616527	33	86617759	HDLS	—
9 ft (RH)	86616539	X	X	XH TS PL BK	Bolted	86616527	33	86617760	HDLS	—
9 ft (LH)	86616696	X	—	XH SS BL BK	Bolted	86616691	33	86617759	HDLS	—
9 ft (RH)	86616697	X	—	XH SS BL BK	Bolted	86616691	33	86617760	HDLS	—
9 ft (LH)	86616712	X	—	XH SS BL BK	Bolted	86616691	33	86617759	86617755	—
9 ft (RH)	86616713	X	—	XH SS BL BK	Bolted	86616691	33	86617760	86617752	—
9 ft (LH)	86616704	X	X	XH SS PL BK	Bolted	86616689	33	86617759	HDLS	—
9 ft (RH)	86616705	X	X	XH SS PL BK	Bolted	86616689	33	86617760	HDLS	—
9 ft (LH)	86616720	X	X	XH SS PL BK	Bolted	86616689	33	86617759	86617755	76417
9 ft (RH)	86616721	X	X	XH SS PL BK	Bolted	86616689	33	86617760	86617752	76417
9 ft (LH)	86616610	X	—	XH SSS BL BK	Bolted	86616588	33	86617759	86617755	76417
9 ft (RH)	86616611	X	—	XH SSS BL BK	Bolted	86616588	33	86617760	86617752	76417
9 ft (LH)	86616626	X	—	XH SSS BL BK	Bolted	86616588	33	86617759	HDLS	—
9 ft (RH)	86616627	X	—	XH SSS BL BK	Bolted	86616588	33	86617760	HDLS	—
9 ft (LH)	86616601	X	—	XH SSS PL BK	Bolted	86616591	33	86617759	86617755	76417
9 ft (RH)	86616602	X	—	XH SSS PL BK	Bolted	86616591	33	86617760	86617752	76417
9 ft (LH)	86616618	X	—	XH SSS PL BK	Bolted	86616591	33	86617759	HDLS	—
9 ft (RH)	86616619	X	—	XH SSS PL BK	Bolted	86616591	33	86617760	HDLS	—

 Original factory-equipped assembly.

QUALITY CUTTING PARTS – ALL MAKES

SECTIONS FOR HAY MACHINES WITH 3" CUT SYSTEMS – VARIOUS BRANDS



CASE IH PART NO.	DEPOT	DIRECT SHIP	THICKNESS	FASTENER SIZE	NUMBER OF HOLES	FINISH	TYPE OF SECTION	PACKAGE QUANTITY	ORDER MULTIPLE	REPLACEMENT FOR	SPECIFIC MODEL OR APPLICATION
HESSTON											
84416820	X	X	HVY	7/32"	2	Plated	TS	25	25	49254	
700705300	X	X	XHVY	7/32"	2	Plated	TS	25	25	700705300	
MACDON											
275522	—	X	REG	7/32"	2	Plated	TS	25	25	22268	
KX211411PDS	—	X	XHVY	7/32"	2	Black	TS	10	10	1327448C1	
345890A1	X	X	XHVY	7/32"	2	Black	SSS	25	25	345890A1	7 serration section for 1052
MASSEY FERGUSON											
275522	X	X	REG	7/32"	2	Plated	TS	25	25	1046776M1	35, 655-785 Windrowers
826722PC2	X	X	XHVY	7/32"	2	Black	US	25	25	683937M1 1036362M1	81, 725, 995 Mower Cond.
KX211411PDS	—	X	XHVY	7/32"	2	Black	TS	10	10	1071707M1	35, 655-785 Windrowers
NEW HOLLAND											
457607R3	X	X	XHVY	7/32"	2	Plated	US	25	25	706226	
826720C3	X	X	XHVY	7/32"	3	Black	TS	25	25	86615988	
700705300	X	X	XHVY	7/32"	2	Plated	TS	25	25	86616527	
NEW IDEA											
826722C2	X	X	XHVY	7/32"	2	Black	US	25	25	W501017E	299 Mower Cond.
700705300	X	X	XHVY	7/32"	2	Plated	TS	25	25	502933	512 & 514 Mower Cond.
SCHUMACHER											
B95013P	—	X	HVY	6mm	2	Black	TS	10	10	420-100-047	14 serration SCH replacement section
VERSATILE											
86015164	X	X	REG	7/32"	2	Plated	TS	25	25	SW1616CR	10-4400 Windrowers
84416053	X	X	REG	7/32"	2	Black	TS	25	25	SW1776CR	10-4400 Windrowers
700705300P	—	X	XHVY	7/32"	2	Plated	TS	10	10	700705300	4812 & 4814 Windrowers

All part numbers shown on this page represent a merchandise pack of 10 sections. With an order multiple of 10, you receive 100 sections (10 packs of 10).

DOUBLE KNIFE DRIVE OVERLAP KITS FOR HAY MACHINES – VARIOUS BRANDS

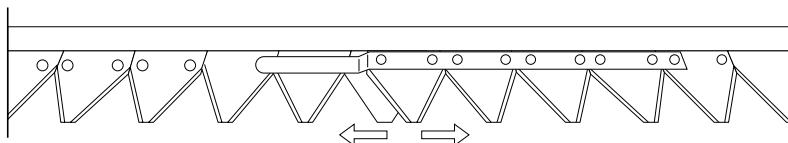

CASE IH PART NO.	DEPOT	DIRECT SHIP	DESCRIPTION	KIT CONTENTS	APPLICATION	PACKAGE QUANTITY	ORDER MULTIPLE
BOLTED							
B92401	—	X	Overlap Repair Kit for Bolted Assemblies 3 - Btm Ctsk TS Chrome Sections (LH) 10 - Ctsk bolts with lock nuts	2 - Top Ctsk TS Chrome Sections (RH)	New Holland	1	1
B92402	—	X	Overlap Repair Kit for Bolted Assemblies 3 - Btm Ctsk TS Black Sections (LH) 10 - Ctsk bolts with lock nuts	2 - Top Ctsk TS Black Sections (RH)	New Holland	1	1

For Hesston Overlap Repair Kits, please refer to Case IH Overlap Repair Kits on page 27.

DISC MOWER KNIVES

MOWER-CONDITIONERS

HAY MACHINES

WINDROWERS

COMBINES

HARDWARE/PARTS

SHAPES CHARTS

HAY MACHINES

KITS

STANDARD SINGLE POINT SECTIONS – HAY MACHINES WITH 3" CUT SYSTEMS



CASE IH PART NO.	DEPOT	DIRECT SHIP	THICKNESS	FASTENER SIZE	NUMBER OF HOLES	FINISH	TYPE OF SECTION	DEPOT ORDER MULTIPLE	DIRECT SHIP ORDER MULTIPLE
67630	X	X	Regular	7/32"	2	Black	US	25	25
457606R3	X	—	XHVY	7/32"	2	Plated	US	25	25
604810	X	X	Regular	7/32"	2	Plated	Smooth	25	25
457604R3	X	—	Regular	7/32"	2	Plated	Smooth	25	25
84416820	X	X	Heavy	7/32"	2	Plated	TS	25	—
049262	X	—	Heavy	7/32"	2	Plated	Smooth	25	—
826722C2	X	X	XHVY	7/32"	2	Black	US	25	25
826724C2	X	X	XHVY	7/32"	2	Black	Smooth	25	25
457605R3	X	—	XHVY	7/32"	2	Plated	Smooth	25	25
826720C3	X	X	XHVY	7/32"	3	Black	TS	25	25
112074P	—	X	XHVY	7/32"	3	Black	SS	—	10
112074H	—	X	XHVY	7/32"	3	Black	SS	—	100
112074A1	X	X	XHVY	7/32"	3	Black	SS	25	25
700705300P	—	X	XHVY	7/32"	2	Plated	TS	—	10
700705300H	—	X	XHVY	7/32"	2	Plated	TS	—	100
700705300	X	X	XHVY	7/32"	2	Plated	TS	25	25
700705300	X	X	XHVY	7/32"	3	Plated	TS	25	25
191256A1	X	X	XHVY	7/32"	3	Plated	TS	25	25
86615988	X	X	XHVY	7/32"	2	Black	TS	25	25
86615988P	—	X	XHVY	7/32"	2	Black	TS	—	10
86616527	X	X	XHVY	7/32"	2	Plated	TS	25	25
86616527P	—	X	XHVY	7/32"	2	Plated	TS	—	10
86616588	X	X	XHVY	7/32"	2	Black	SSS	25	25
86616591	X	X	XHVY	7/32"	2	Plated	SSS	25	25
86616689	X	X	XHVY	7/32"	2	Plated	SS	25	25
86616689P	—	X	XHVY	7/32"	2	Plated	SS	—	10
86616691	X	X	XHVY	7/32"	2	Black	SS	25	25
86616691P	—	X	XHVY	7/32"	2	Black	SS	—	10
823711C3	X	—	XHVY	1/4"	2	Plated	US	25	25
823713C3	X	X	XHVY	1/4"	2	Plated	TS	25	25

1) "P" suffix part numbers shown on this page represent a merchandise pack of 10 sections. With an order multiple of 10, you receive 100 sections (10 packs of 10).

2) "H" suffix part numbers shown on this page are priced and ordered per section. With an order multiple of 100, you receive 100 sections (Bulk Packed).

3) All other part numbers available from the Depot are order multiples of the package quantity as shown.

OVERLAP SECTIONS – CASE IH HAY MACHINES WITH DOUBLE KNIFE DRIVE PLATFORMS

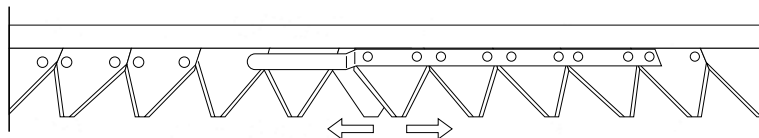

CASE IH PART NO.	DEPOT	DIRECT SHIP	THICKNESS	FASTENER SIZE	FINISH	TYPE OF SECTION	PACKAGE QUANTITY	DEPOT ORDER MULTIPLE	DIRECT SHIP ORDER MULTIPLE
51200279	X	—	HVY	7/32"	Plated	Sawtooth	25	25	—
51200281	X	X	HVY	7/32"	Plated	TS	25	25	25
86615986	X	X	XHVY	7/32"	Black	TS	10	10	25
86615987	X	X	XHVY	7/32"	Black	TS	25	25	25
86616528	X	X	XHVY	7/32"	Plated	TS	10	10	25
86616529	X	X	XHVY	7/32"	Plated	TS	10	10	25
86616589	X	X	XHVY	7/32"	Black	SSS	25	25	25
86616590	X	X	XHVY	7/32"	Black	SSS	10	10	25
86616592	X	X	XHVY	7/32"	Plated	SSS	10	10	25
86616593	X	X	XHVY	7/32"	Plated	SSS	25	25	25
86616692	X	X	XHVY	7/32"	Plated	SS	10	10	25
86616693	X	X	XHVY	7/32"	Plated	SS	10	10	25
86615985	X	X	XHVY	7/32"	Black	TS Tomahawk	5	5	5

OVERLAP KITS – CASE IH (HESSTON) HAY MACHINES WITH DOUBLE KNIFE DRIVE PLATFORMS

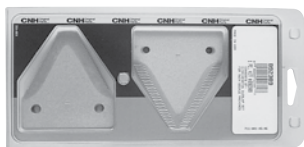

CASE IH PART NO.	DEPOT	DIRECT SHIP	DESCRIPTION	KIT CONTENTS	PACKAGE QUANTITY	ORDER MULTIPLE	DIRECT SHIP ORDER MULTIPLE
B92389		X	Overlap Repair Kit for Riveted Assemblies 2 - 51200279 Top Ctsk Sawtooth (LH) 10 - Ctsk Rivets for above	3 - 51200281 Btm Ctsk Sections (RH)	1	1	1
86616560	X	X	Overlap Card 2 - 86615986 Top Ctsk Sections 1 - 86615985 Tomahawk Section 13 Nuts & Bolts for above	3 - 86615987 Btm Ctsk Sections	1	1	1
86616546	X	X	Overlap Card 2 - 86616528 Top Ctsk Sections 1 - 86615985 Tomahawk Section 13 Nuts & Bolts for above	3 - 86616529 Btm Ctsk Sections	1	1	1
86616634	X	X	Overlap Card 2 - 86616589 Top Ctsk Sections 1 - 86615985 Tomahawk Section 13 Nuts & Bolts for above	3 - 86616590 Btm Ctsk Sections	1	1	10
86616635	X	X	Overlap Card 2 - 86616592 Ctsk Sections 1 - 86615985 Tomahawk Section 13 Nuts & Bolts for above	3 - 86616593 Btm Ctsk Sections	1	1	10
86616728	X	X	Overlap Card 2 - 86616694 Top Ctsk Sections 1 - 86615985 Tomahawk Section 13 Nuts & Bolts for above	3 - 86616695 Btm Ctsk Sections	1	1	1
86616729	X	X	Overlap Card 2 - 86616692 Top Ctsk Sections 1 - 86615985 Tomahawk Section 13 Nuts & Bolts for above	3 - 86616693 Btm Ctsk Sections	1	1	1

See hardware on page 54 & 55 for replacement fasteners.

HAY MACHINES

KITS

END SECTIONS – HAY MACHINES & COMBINES

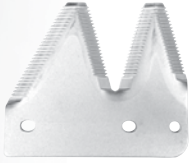

CASE IH PART NO.	DEPOT	DIRECT SHIP	THICKNESS	SIDE USED	FASTENER SIZE	NUMBER OF HOLES	FINISH	TYPE OF SECTION	PACKAGE QUANTITY	DEPOT ORDER MULTIPLE	DIRECT SHIP ORDER MULTIPLE
748145	X	—	XHVY	LH	7/32"	2 Rnd	Plated	TS	1	1	—
700705463	X	X	XHVY	RH	7/32"	3 Rnd	Plated	TS	5	5	5
86617760	X	X	XHVY	RH	7/32"	3 Rnd	Black	TS	5	5	5
700705462	X	X	XHVY	LH	7/32"	3 Rnd	Plated	TS	5	5	5
ZA290658	X	—	XHVY	RH	7/32"	2 Slots	Plated	Smooth	5	5	—
86617759	X	X	XHVY	LH	7/32"	3 Rnd	Black	TS	5	5	5
324070A1	X	—	XHVY	RH	7/32"	3 Rnd	Black	TS	5	5	—
B92387*	—	X	XHVY	RH	7/32"	3 Rnd	Black	TS	1	1	15
B92388*	—	X	XHVY	LH	7/32"	3 Rnd	Black	TS	1	1	15
86616976*	X	X	XHVY	RH	7/32"	3 Rnd	Black	TS	1	1	1
86617121	X	X	XHVY	RH & LH	7/32"	3 Rnd	Black	TS	1	1	1

* Refers to End Section Kits.

HALF SECTIONS – HAY MACHINES & COMBINES



CASE IH PART NO.	DEPOT	DIRECT SHIP	THICKNESS	SIDE USED	FASTENER SIZE	NUMBER OF HOLES	FINISH	TYPE OF SECTION	PACKAGE QUANTITY	ORDER MULTIPLE
1316030C2	X	—	XHVY	LH	7/32"	2	Black	Smooth	5	5
559269R2	X	—	REG	LH	7/32"	2	Black	TS	10	10
1319392C2	X	—	XHVY	LH	7/32"	2	Black	Smooth	5	5
ZA502643	X	—	XHVY	RH	7/32"	2	Chrome	Blank	1	1
48868	X	—	REG	RH	7/32"	2	Chrome	Smooth	10	10



IT'S NOT REBUILT. IT'S REBORN.

CASE IH REMANUFACTURED PARTS. MORE RELIABLE
THAN A REBUILD. MORE PRECISE THAN A WILL-FIT.



To maximize uptime and keep your equipment running at peak performance, choose Case IH remanufactured parts. Case IH delivers engineered components that aren't just close to OEM specs, they are OEM specs. In fact, they even come with a warranty that's equal to or better than the competition. With Case IH remanufactured parts, you'll get maximum performance from your equipment and more money in your pocket.

To learn more, see your local Case IH dealer or visit www.caseih.com.



© 2014 CNH Industrial America LLC. All rights reserved. Case IH is a trademark registered in the United States and many other countries, owned by or licensed to CNH Industrial N.V., its subsidiaries or affiliates. CNH Industrial Reman is a trademark in the United States and many other countries, owned by or licensed to CNH Industrial N.V., its subsidiaries or affiliates. www.caseih.com



WINDROWERS



WINDROWERS

- 31** 75 WINDROWER
- 31** 721, 725, 730, 736, 742, 750, 6000 & 6500 WINDROWERS
- 32** 1075, 1085 & 1275 WINDROWERS
- 32** 4000, 5000, 5500 SINGLE AUGER & DRAPER
- 34** 4000, 5000, 5500 DUAL AUGER
- 34** 8210, 8220, 8230 & 8240 PT
- 35** 8820 SINGLE AUGER HEADER
- 35** 8830 & 525 AUGER HEADER
- 36** 8840, 8380 & 625 DUAL AUGER HEADER
- 37** 8820, 8830 & 8840 DRAPER HEADER
- 37** 8820 & 425 SHIFTABLE DRAPER HEADER
- 38** DHX 2 DRAPER HEADER
- 38** HESSTON WINDROWER MODELS 520, 620, 1014, 6200, 6400, 6450 & 6465
- 39** SCHUMACHER® EASY CUT PARTS

KNIFE ASSEMBLIES – CASE IH

75 WINDROWER

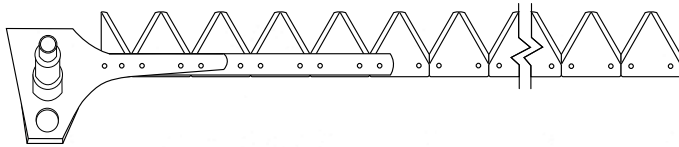

KNIFE ASSEMBLY	AVAILABILITY		PLAT-FORM LENGTH	NUMBER OF KNIFE SECTIONS	KNIFE SECTION	TYPE OF SECTION	FASTENERS				FASTENER LOCKNUT (IF REQ.)	KNIFE CLIPS				HEAD NUMBER
	DEPOT	DIRECT SHIP					KNIFEHEAD		ASSEMBLY			KNIFEHEAD		ASSEMBLY		
							PART NO.	QTY.	PART NO.	QTY.		PART NO.	QTY.	PART NO.	QTY.	
BOLTED																
B91610	—	X	21 ft	80	700705300	XHVY-TS-PL	86507781	1	86507777	159	848083	—	1	84389548	13	824639C1
				4	823713C3	XHVY-TS-PL	1979166C1	2								

721, 725, 730, 736, 742, 750, 6000 & 6500 WINDROWERS

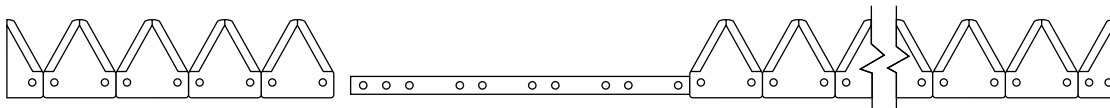

KNIFE ASSEMBLY	AVAILABILITY		PLAT-FORM LENGTH	NUMBER OF KNIFE SECTIONS	KNIFE SECTION	TYPE OF SECTION	FASTENERS				FASTENER LOCKNUT (IF REQ.)	KNIFE CLIPS				HEAD NUMBER
	DEPOT	DIRECT SHIP					KNIFEHEAD		ASSEMBLY			KNIFEHEAD		ASSEMBLY		
							PART NO.	QTY.	PART NO.	QTY.		PART NO.	QTY.	PART NO.	QTY.	
BOLTED																
ZAK1337024	—	X	21 ft	83	700705300	XHVY-TS-PL	700706479	11	86507777	159	848083	—	—	B93356	20	HDLS
ZAK80648	—	X	25 ft	99	700705300	XHVY-TS-PL	700706479	11	86507777	191	848083	—	—	B93356	24	HDLS
ZAK80650	—	X	30 ft	119	700705300	XHVY-TS-PL	700706479	11	86507777	231	848083	—	—	B93356	29	HDLS

My Shed™

Mobile App 2.1

MANAGE YOUR EQUIPMENT FROM YOUR SMARTPHONE.

SEE PAGE 2 FOR DETAILS.



Google Play™
for Android™



Apple® Store
for iPhone®



WINDROWERS

KNIFE ASSEMBLIES – CASE IH

1075, 1085 & 1275 WINDROWERS

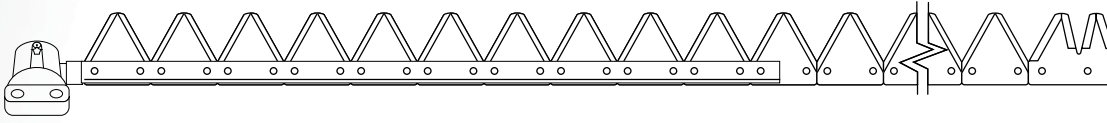

KNIFE ASSEMBLY	AVAILABILITY		PLAT-FORM LENGTH	NUMBER OF KNIFE SECTIONS	KNIFE SECTION	TYPE OF SECTION	FASTENERS				FASTENER LOCKNUT (IF REQ.)	KNIFE CLIPS			
	DEPOT	DIRECT SHIP					KNIFEHEAD		ASSEMBLY			KNIFEHEAD		ASSEMBLY	
							PART NO.	QTY.	PART NO.	QTY.		PART NO.	QTY.	PART NO.	QTY.
BOLTED															
B92537	—	X	14 ft	56	84416820	HVY-TS-PL	86517390	21	86507777	93	848083	84389554	2	84389548	12
B92539	—	X	14 ft	56	84416820	HVY-TS-PL	86517390	21	86507777	93	848083	84389554	2	84389548	12

4000, 5000 & 5500 WINDROWERS (SINGLE AUGER & DRAPER HEADERS)

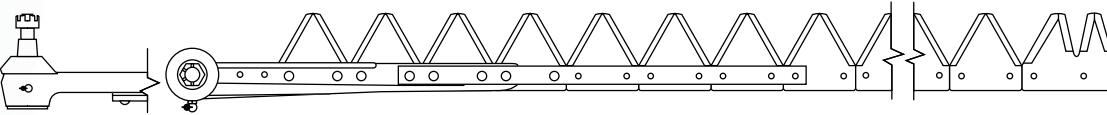

KNIFE ASSEMBLY	AVAILABILITY		PLAT-FORM LENGTH	NUMBER OF KNIFE SECTIONS	KNIFE SECTION	TYPE OF SECTION	FASTENERS				FASTENER LOCKNUT (IF REQ.)	KNIFE CLIPS				HEAD NUMBER
	DEPOT	DIRECT SHIP					KNIFEHEAD		ASSEMBLY			KNIFEHEAD		ASSEMBLY		
							PART NO.	QTY.	PART NO.	QTY.		PART NO.	QTY.	PART NO.	QTY.	
BOLTED																
ZAK827813	—	X	12.5 ft	44	457607R3 823711C3	XHVY-US-PL XHVY-US-PL	B92259 86507779	8	86507777 86507778-17	73	848083	84389554 7	1	84389548	11	824594C91
ZAK827813T	—	X	12.5 ft	44	700705300 823713C3	XHVY-TS-PL XHVY-TS-PL	B92259 86507779	8	86507777 86507778-17	73	848083	84389554 7	1	84389548	11	824594C91
ZAK827814	—	X	14.5 ft	52	457607R3 823711C3	XHVY-US-PL XHVY-US-PL	B92259 86507779	8	86507777 86507778-17	89	848083	84389554 7	1	84389548	13	824594C91
ZAK831607	—	X	14.5 ft	52	700705300 823713C3	XHVY-TS-PL XHVY-TS-PL	B92259 86507779	8	86507777 86507778-17	89	848083	84389554 7	1	84389548	13	824594C91
ZAK827815T	—	X	16.5 ft	60	700705300 823713C3	XHVY-TS-PL XHVY-TS-PL	B92259 86507779	8	86507777 86507778-17	105	848083	84389554 7	1	84389548	15	824594C91
ZAK827816	—	X	19.5 ft	72	604800 823711C3	REG-US-PL XHVY-US-PL	B92259 86507779	8	86507777 86507778-17	129	848083	84389554 7	1	84389548	18	824594C91
B91609	—	X	19.5 ft	72	700705300 823713C3	XHVY-TS-PL XHVY-TS-PL	B92259 86507779	8	86507777 86507778-17	129	848083	84389554 7	1	84389548	18	824594C91
B91608	—	X	24.5 ft	92	700705300 823713C3	XHVY-TS-PL XHVY-TS-PL	B92259 86507779	8	86507777 86507778-17	159	848083	84389554	1	84389548	23	824594C91
ZAK827830T	—	X	24.5 ft	92	700705300 823713C3	XHVY-TS-PL XHVY-TS-PL	B92259 86507779	8	86507777 86507778-17	159	848083	84389554 7	1	84389548	23	824594C91
RIVETED																
827813C92	X	—	12.5 ft	44	457607R3 823711C3	XHVY-US-PL XHVY-US-PL	MA133M 45-418 990325R91	7 4 4	B91969 B91970-17	73	—	824981C1	2	613842R2	9	824594C91
827814C92	X	—	14.5 ft	52	457607R3 823711C3	XHVY-US-PL XHVY-US-PL	MA133M 45-418 990325R91	7 4 4	B91969 B91970-17	89	—	824981C1	2	613842R2	11	824594C91
827721C92	X	—	14.5 ft	52	700705300 823713C3	XHVY-TS-PL XHVY-TS-PL	MA133M 45-418 990325R91	7 4 4	B91969 B91970-17	89	—	824981C1	2	613842R2	11	824594C91
1281481C92	X	—	19.5 ft	72	700705300 823713C3	XHVY-TS-PL XHVY-TS-PL	MA133M 45-418 990325R91	7 4 4	B91969 B91970-17	129	—	824981C1	2	613842R2	16	824594C91

KEEP THE UNEXPECTED FROM IMPACTING YOUR PRODUCTION.

Run your operation longer and stronger with a Shock Protection System Hub Kit. When your mower's blades come into contact with rocks, branches or other obstacles, the stress can damage your mower modules. These easy-to-install shock hubs minimize spline shear and eliminate cutter bar gear teeth failure if an obstacle is encountered. This cutting and baling season, Be Ready for the unexpected.



SHOCK PROTECTION SYSTEM HUB RETROFIT KIT

Part No. 87602273

The Shock Protection System Hub Retrofit Kit allows you to retrofit older-model mower conditioners. It includes a hub seal which prevents metal fines from entering module components and damaging them. Components and installation instructions are included for two modules.

Application: DCX91, DCX101, DCX131, DCX161, MDX71, MDX81, MDX91, RDX131, RDX161, RDX181



SHOCK PROTECTION SYSTEM HUB REPAIR KIT

Part No. 87580643

The Shock Protection System Hub Repair Kit makes in-field repairs fast and easy. Components and installation instructions are included for one module.

Application: All models except RD163, RD193



For more information, see your local Case IH dealer or visit partstore.caseih.com today.



WINDROWERS

KNIFE ASSEMBLIES – CASE IH

4000, 5000 & 5500 WINDROWERS (DUAL AUGER)

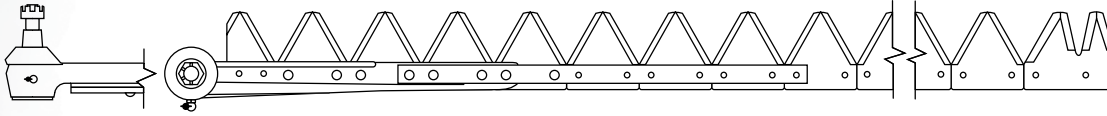

KNIFE ASSEMBLY	AVAILABILITY		PLAT-FORM LENGTH	NUMBER OF KNIFE SECTIONS	KNIFE SECTION	TYPE OF SECTION	FASTENERS				FASTENER LOCKNUT (IF REQ.)	KNIFE CLIPS				HEAD NUMBER
	DEPOT	DIRECT SHIP					KNIFEHEAD		ASSEMBLY			KNIFEHEAD		ASSEMBLY		
							PART NO.	QTY.	PART NO.	QTY.		PART NO.	QTY.	PART NO.	QTY.	
BOLTED																
ZAK827724T	—	X	12 ft	43 4	700705300 823713C3	XHVY-TS-PL XHVY-TS-PL	B92259 86507779	8 7	86507777	89	848083	84389554	1	84389548	11	824594C91
ZAK827701	—	X	14 ft	51 4	700705300 823713C3	XHVY-TS-PL XHVY-TS-PL	B92259 86507779	8 7	86507777	97	848083	84389554	1	84389548	13	824594C91

8210, 8220, 8230 & 8240 PT WINDROWERS

Hesston 1200

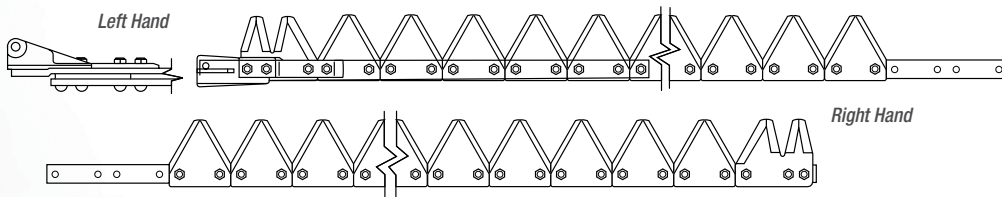

KNIFE ASSEMBLY	AVAILABILITY		PLAT-FORM LENGTH	NUMBER OF KNIFE SECTIONS	KNIFE SECTION	TYPE OF SECTION	FASTENERS				FASTENER LOCKNUT (IF REQ.)	KNIFE CLIPS				HEAD NUMBER
	DEPOT	DIRECT SHIP					KNIFEHEAD		ASSEMBLY			KNIFEHEAD		ASSEMBLY		
							PART NO.	QTY.	PART NO.	QTY.		PART NO.	QTY.	PART NO.	QTY.	
BOLTED																
700709888 15 ft (LH)	X	—	All	58	84416820	HVY-TS-PL	86507779 700706479	10 4	86507777	105	848083	—	—	700111204	12	700709889
700709895 6 ft (RH)	X	—	21 ft	20	84416820	HVY-TS-PL	—	—	86507777	43	848083	—	—	700111204	1	HDLS
700709896 10 ft (RH)	X	—	25 ft	36	84416820	HVY-TS-PL	—	—	86507777	75	848083	—	—	700111204	4	HDLS
700709897 15 ft (RH)	X	—	30 ft	56	84416820	HVY-TS-PL	—	—	86507777	115	848083	—	—	700111204	7	HDLS
700710967 20 ft (RH)	X	—	35 ft	76	84416820	HVY-TS-PL	—	—	86507777	155	848083	—	—	700111204	10	HDLS

KNIFE ASSEMBLIES – CASE IH

8820 SINGLE AUGER HEADER 14' & 16' WINDROWERS

Hesston 8100

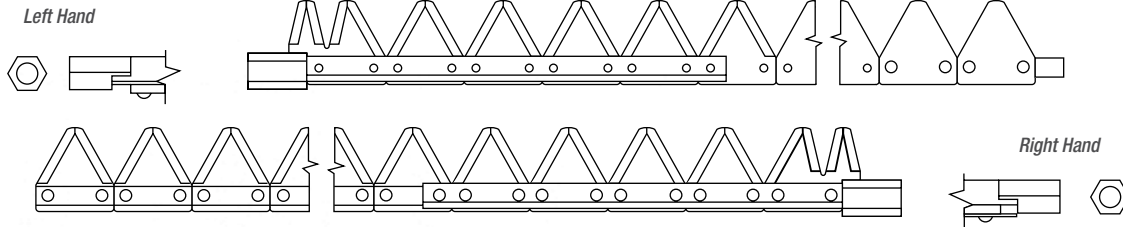

KNIFE ASSEMBLY	AVAILABILITY		PLAT-FORM LENGTH	NUMBER OF KNIFE SECTIONS	KNIFE SECTION	TYPE OF SECTION	FASTENERS				FASTENER LOCKNUT (IF REQ.)	KNIFE CLIPS				HEAD NUMBER		
	DEPOT	DIRECT SHIP					KNIFEHEAD		ASSEMBLY			PART NO.	QTY.	KNIFEHEAD			ASSEMBLY	
							PART NO.	QTY.	PART NO.	QTY.				PART NO.	QTY.		PART NO.	QTY.
BOLTED																		
700709577 7 ft (LH)	X	—	14 ft	25 2	700705300 51200279	XHVV-TS-PL SAWTOOTH	86517390	11	86507777 137636	41 5	848083	—	—	700109725	6	6821078		
700709578 7 ft (RH)	X	—	14 ft	25 3	700705300 51200281	XHVV-TS-PL OVERLAP	86517390	11	86507777 137636	41 6	848083	—	—	700109725	6	—		
700709579 8 ft (LH)	X	—	16 ft	29 2	700705300 51200279	XHVV-TS-PL SAWTOOTH	86517390	11	86507777 137636	49 5	848083	—	—	700109725	7	6821078		
700709580 8 ft (RH)	X	—	16 ft	29 3	700705300 51200281	XHVV-TS-PL OVERLAP	86517390	11	86507777 137636	49 6	848083	—	—	700109725	7	—		

8830 & 525 AUGER HEADER (SINGLE SICKLE) 12' & 14' WINDROWERS

Hesston 8200, 8010

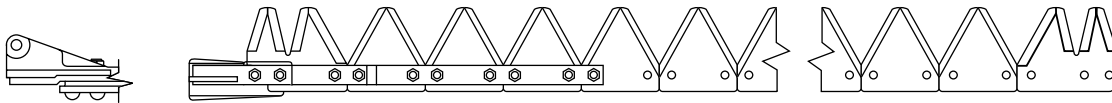

KNIFE ASSEMBLY	AVAILABILITY		PLAT-FORM LENGTH	NUMBER OF KNIFE SECTIONS	KNIFE SECTION	TYPE OF SECTION	FASTENERS				FASTENER LOCKNUT (IF REQ.)	KNIFE CLIPS				HEAD NUMBER		
	DEPOT	DIRECT SHIP					KNIFEHEAD		ASSEMBLY			PART NO.	QTY.	KNIFEHEAD			ASSEMBLY	
							PART NO.	QTY.	PART NO.	QTY.				PART NO.	QTY.		PART NO.	QTY.
BOLTED																		
700709622	X	X	12 ft	46	700705300	XHVV-TS-PL	86507778 1979166C1 700706479	6 2 2	86507777	88	848083	N/A	N/A	700109725 700134757*	13 20	700111003		
700709623	X	X	14 ft	54	700705300	XHVV-TS-PL	86507778 1979166C1 700706479	6 2 2	86507777	104	848083	N/A	N/A	700109725 700134757*	15 24	700111003		
ZAK7709623	—	X	14 ft	54	700705300	XHVV-TS-PL	86507778 1979166C1 700706479	6 2 2	86507777	104	848083	N/A	N/A	700109725 700134757*	15 24	HDLS		

*New Knife Clips for 525 Auger Header only.

WINDROWERS

KNIFE ASSEMBLIES – CASE IH

8840, 8380 14', 16', 18' & 625 DUAL AUGER HEADER WINDROWERS

Hesston 8400, 1170 & 8020

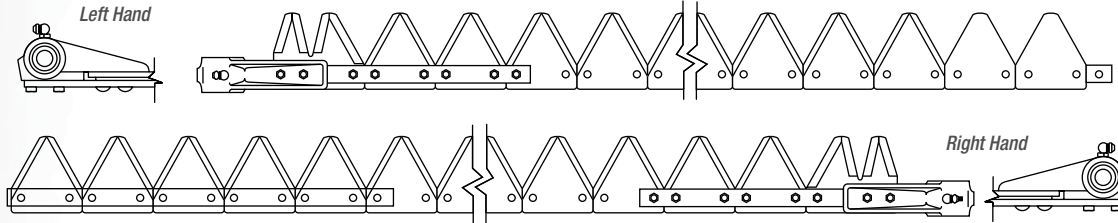

KNIFE ASSEMBLY	AVAILABILITY		PLAT-FORM LENGTH	NUMBER OF KNIFE SECTIONS	KNIFE SECTION	TYPE OF SECTION	FASTENERS				FASTENER LOCKNUT (IF REQ.)	KNIFE CLIPS				HEAD NUMBER
	DEPOT	DIRECT SHIP					KNIFEHEAD		ASSEMBLY			KNIFEHEAD	ASSEMBLY			
							PART NO.	QTY.	PART NO.	QTY.			PART NO.	QTY.	PART NO.	
BOLTED																
700715165 7 ft (LH)	X	X	14 ft	25 2	700705300 51200279	XHVY-TS-PL SAWTOOTH	86507778 700706479	6 2	86507777 700715160	45 5	848083	—	—	700109725 700134758* 00117849*	6 10 1	700114594
700715166 7 ft (RH)	X	X	14 ft	25 3	700705300 51200281	XHVY-TS-PL OVERLAP	86507778 700706479	6 2	86507777 700715160 86517390	40 6 5	848083	—	—	700109725 00134757*	6 11	700114594
B95021 7 ft (LH)	—	X	14 ft	25 2	191256A1 51200279	XHVY-SS-PL SAWTOOTH	86507778 700706479	6 2	86507777 700715160	45 5	848083	—	—	700109725 700134758* 700109725*	6 10 1	700114594
B95022 7 ft (RH)	—	X	14 ft	25 3	191256A1 51200281	XHVY-SS-PL OVERLAP	86507778 700706479	6 2	86507777 86517390 700715160	45 6 5	848083	—	—	700109725 700134757*	6 11	700114594
700715167 8 ft (LH)	X	X	16 ft	29 2	700705300 51200279	XHVY-TS-PL SAWTOOTH	86507778 700706479	6 2	86507777 700715160	53 5	848083	—	—	700109725 700134758* 700109725*	7 12 1	700114594
700715168 8 ft (RH)	X	X	16 ft	29 3	700705300 51200281	XHVY-TS-PL OVERLAP	86507778 700706479	6 2	86507777 700715160 700715170	48 6 5	848083	—	—	700109725 700134757*	7 13	700114594
B95023 8 ft (LH)	—	X	16 ft	29 2	191256A1 51200279	XHVY-SS-PL SAWTOOTH	86507778 700706479	6 2	86507777 700715160	53 5	848083	—	—	700109725 700134758* 700109725*	7 12 1	700114594
B95024 8 ft (RH)	—	X	16 ft	29 3	191256A1 51200281	XHVY-SS-PL OVERLAP	86507778 700706479	6 2	86507777 86517390 70071560	48 6 5	848083	—	—	700109725 700134757*	7 13	700114594
B95027 8 ft (LH)	—	X	16 ft	29 2	700705300 51200279	XHVY-TS-PL SAWTOOTH	—	—	86507777 86517390	53 5	848083	—	—	700109725 700134758* 700109725*	7 12 1	HDLS
B95028 8 ft (RH)	—	X	16 ft	29 3	700705300 51200281	XHVY-TS-PL OVERLAP	—	—	86507777 51200830 86517390	48 6 5	848083	—	—	700109725 700134757*	7 13	HDLS
700715778 9 ft (LH)	X	X	18 ft	33 2	700705300 51200279	XHVY-TS-PL SAWTOOTH	86507778 700706479	6 2	86507777 700715160	61 5	848083	—	—	700134758* 700109725*	14 1	700114594
700715779 9 ft (RH)	X	X	18 ft	33 3	700705300 51200281	XHVY-TS-PL OVERLAP	86507779 86507778 700715170	6 2 5	86507777 700715160	56 6	848083	—	—	700134757*	15	700114594

*New Knife Clips for 625 Dual Auger Header only. 700109725 is a Center Knife Clip for 625 Dual Auger Header.

KNIFE ASSEMBLIES – CASE IH

8820, 8830 & 8840 (15', 18' & 21') DRAPER HEADERS

Hesston 8100, 8200 & 8400

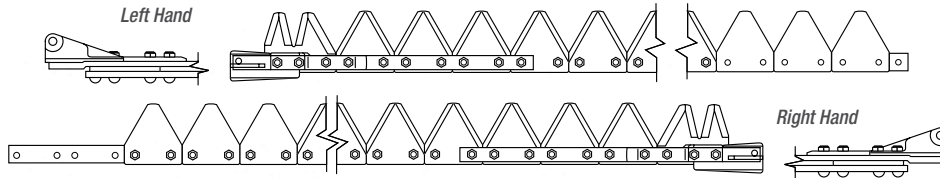

KNIFE ASSEMBLY	AVAILABILITY		PLAT-FORM LENGTH	NUMBER OF KNIFE SECTIONS	KNIFE SECTION	TYPE OF SECTION	FASTENERS				FASTENER LOCKNUT (IF REQ.)	KNIFE CLIPS				HEAD NUMBER
	DEPOT	DIRECT SHIP					KNIFEHEAD		ASSEMBLY			KNIFEHEAD		ASSEMBLY		
							PART NO.	QTY.	PART NO.	QTY.		PART NO.	QTY.	PART NO.	QTY.	
BOLTED																
700715808 9 ft (LH)	X	—	18 ft	32	84416820	HVY-TS-PL	700706479	4	86507777	57	848083	—	—	700111204	5	700111003
				3	51200279	SAWTOOTH	86507778	6	700715160	7						
700715809 9 ft (RH)	X	—	18 ft	33	84416820	HVY-TS-PL	700706479	4	86507777	55	848083	—	—	700111204	5	700116709
				3	51200281	OVERLAP	86507778	6	86507779	4						
700715810 11 ft (LH)	X	—	21 ft	38	84416820	HVY-TS-PL	700706479	4	86507777	69	848083	—	—	700111204	6	700111003
				3	51200279	SAWTOOTH	86507778	6	700715160	7						
700715811 10 ft (RH)	X	—	21 ft	39	84416820	HVY-TS-PL	700706479	4	86507777	67	848083	—	—	700111204	6	700116709
				3	51200281	OVERLAP	86507778	6	86507779	4						

8820 & 425 SHIFTABLE DRAPER HEADER (21', 25' & 30')

Hesston 8100 & 8050

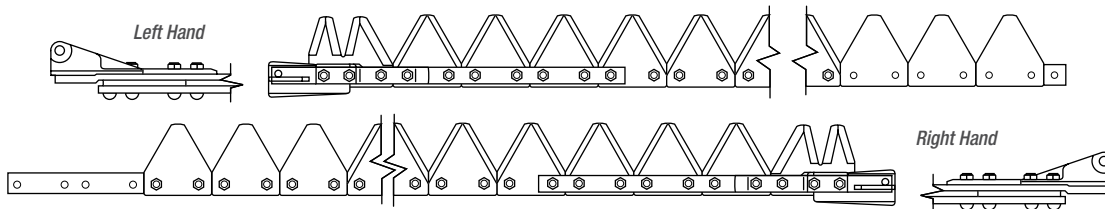

KNIFE ASSEMBLY	AVAILABILITY		PLAT-FORM LENGTH	NUMBER OF KNIFE SECTIONS	KNIFE SECTION	TYPE OF SECTION	FASTENERS				FASTENER LOCKNUT (IF REQ.)	KNIFE CLIPS				HEAD NUMBER
	DEPOT	DIRECT SHIP					KNIFEHEAD		ASSEMBLY			KNIFEHEAD		ASSEMBLY		
							PART NO.	QTY.	PART NO.	QTY.		PART NO.	QTY.	PART NO.	QTY.	
BOLTED																
700715810 11 ft (LH)	X	—	21 ft	38	84416820	HVY-TS-PL	700706479	4	86507777	69	848083	—	—	700134757*	12	700111003
				3	51200279	SAWTOOTH	86507778	6	700715160	7				6832703*	12	
															1	
700715811 10 ft (RH)	X	—	21 ft	39	84416820	HVY-TS-PL	700706479	4	86507777	67	848083	—	—	700148847*	8	700116709
				3	51200281	OVERLAP	86507778	6	86507779	4					12	
															8	
700715814 13 ft (LH)	X	—	25 ft	46	84416820	HVY-TS-PL	700706479	4	86507777	85	848083	—	—	700134757*	12	700111003
				3	51200279	SAWTOOTH	86507778	6	700715160	7				6832703*	14	
															1	
700715815 12 ft (RH)	X	—	25 ft	47	84416820	HVY-TS-PL	700706479	4	86507777	83	848083	—	—	700148847*	10	700116709
				3	51200281	OVERLAP	86507778	6	86507779	4					16	
															10	
700715816 15 ft (LH)	X	—	30 ft	56	84416820	HVY-TS-PL	700706479	4	86507777	105	848083	—	—	700134757*	12	700111003
				3	51200279	SAWTOOTH	86507778	6	700715160	7				6832703*	18	
															1	
700715817 15 ft (RH)	X	—	30 ft	57	84416820	HVY-TS-PL	700706479	4	86507777	103	848083	—	—	700148847*	12	700116709
				3	51200281	OVERLAP	86507778	6	86507779	4					16	

*New Knife Clips for 425 Dual Draper Auger. 6832703 is a Center Knife Clip for 425 Shiftable Draper Header.

WINDROWERS

KNIFE ASSEMBLIES – CASE IH

DHX 2 SERIES DRAPER HEADER



KNIFE ASSEMBLY	AVAILABILITY		PLAT-FORM LENGTH	NUMBER OF KNIFE SECTIONS	KNIFE SECTION	TYPE OF SECTION	FASTENERS				FASTENER LOCKNUT (IF REQ.)	KNIFE CLIPS				HEAD NUMBER
	DEPOT	DIRECT SHIP					KNIFEHEAD		ASSEMBLY			KNIFEHEAD		ASSEMBLY		
							PART NO.	QTY.	PART NO.	QTY.		PART NO.	QTY.	PART NO.	QTY.	
BOLTED																
87056009	X	—	18 ft (LH)	31	86615988	XHVY-TS-BL	86507778	4	86507777	56	848083	—	—	86630786	9	HDLS
87056010	X	—	18 ft (RH)	34	86615988	XHVY-TS-BL	86507778	4	86507777	57	848083	—	—	86630786	9	HDLS
87056011	X	—	21 ft (LH)	37	86615988	XHVY-TS-BL	86507778	4	86507777	60	848083	—	—	86630786	10	HDLS
87056012	X	—	21 ft (RH)	40	86615988	XHVY-TS-BL	86507778	4	86507777	61	848083	—	—	86630786	10	HDLS
87056013	X	—	25 ft (LH)	45	86615988	XHVY-TS-BL	86507778	4	86507777	76	848083	—	—	86630786	12	HDLS
87056014	X	—	25 ft (RH)	48	86615988	XHVY-TS-BL	86507778	4	86507777	77	848083	—	—	86630786	12	HDLS
87056015	X	—	30 ft (LH)	55	86615988	XHVY-TS-BL	86507778	4	86507777	96	848083	—	—	86630786	15	HDLS
87056016	X	—	30 ft (RH)	58	86615988	XHVY-TS-BL	86507778	4	86507777	97	848083	—	—	86630786	14	HDLS
87056017	X	—	36 ft (LH)	69	86615988	XHVY-TS-BL	86507778	4	86507777	114	848083	—	—	86630786	19	HDLS
87056018	X	—	36 ft (RH)	70	86615988	XHVY-TS-BL	86507778	4	86507777	113	848083	—	—	86630786	17	HDLS

KNIFE ASSEMBLIES – ALL- MAKES

HESSTON WINDROWER MODELS 520, 620, 1014, 6200, 6400, 6450 & 6465

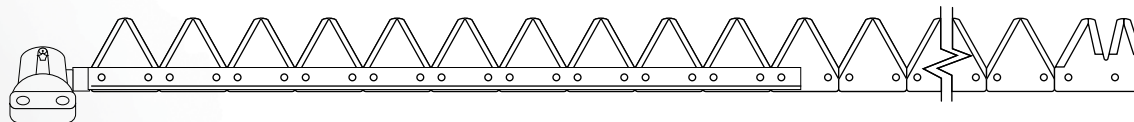

KNIFE ASSEMBLY	DEPOT	DIRECT SHIP	REPLACEMENT FOR	PLATFORM LENGTH	NUMBER OF KNIFE SECTIONS	REPLACEMENT KNIFE SECTION	TYPE OF SECTION	WITH KNIFEHEAD OR HEADLESS
BOLTED								
B92539	—	X	6497119	14 ft	56	84416820	HVY-TS-PL	w/ Long Head

SCHUMACHER® EASY CUT PARTS

SECTIONS

PART NUMBER	DESCRIPTION
86561692	Schumacher Pro Cut-Fine 11 Teeth/in
84158455	Schumacher Pro Cut-Coarse 7 Teeth/in
84242662	Overlap Section
87037117	Twin Point End Section
84223452	Overlap Section w/Bolts

GUARDS

PART NUMBER	DESCRIPTION
84314629	Open Top Center Guard 12mm for Double Drive
84314630	Triple Guard 12mm Easy Cut II Std.
86561684	Open Top First Guard 12mm
86561686	Standard Guard 12mm Easy Cut II Std.

REPAIR PARTS

PART NUMBER	DESCRIPTION
84476750	Spacer Plate 7mm/6-Hole
86563534	Nylon Ring for Knifeheads
87670866	Bottom Bridge Roller/Newer Style 2007
84158453	Center Bridge Roller/Overlap Strap on Double Drive
84158454	Spacer Bushing for Center Roller
84476751	2-Hole Wear Plate, 7mm
84476752	3-Hole Wear Plate, 7mm
84476754	4-Hole Wear Plate, 7mm
84476750	6-Hole Wear Plate, 7mm



PART NO. 86561692



PART NO. 84242662



PART NO. 86561684



PART NO. 84314629



PART NO. 84158453



PART NO. 84314630



PART NO. 87670866



PART NO. 86561686

DISC MOWER KNIVES

MOWER-COONDITIONERS

HAY MACHINES

WINDROWERS

COMBINES

HARDWARE/PARTS

SHAPES CHARTS

COMBINES



COMBINES

- 41** 3020 HEADERS
- 42** 2010 & 2020 HEADERS - 3" SYSTEM
- 42** 1010 & 1020 HEADERS - 3" SYSTEM, KNIVES
- 43** 1010 & 1020 HEADERS - 3" SPLIT KNIFE SYSTEM
- 44** 1010 & 1020 1-1/2" SYSTEM
- 44** 820 HEADER (FLEX)
- 45** 810 & 820 HEADER (500 CPM)-NON FLOAT
- 45** 810 HEADER (600 CPM)-NON FLOAT
- 46** 1042 & 1052 DRAPER HEADERS
- 47** ALL-MAKES
- 47 - 49** KITS

KNIFE ASSEMBLIES – CASE IH

3020 HEADERS FOR COMBINES

KNIFE ASSEMBLY	AVAILABILITY		PLAT-FORM LENGTH	NUMBER OF KNIFE SECTIONS	KNIFE SECTION	TYPE OF SECTION	HARDWARE				FASTENER LOCKNUT (IF REQ.)	SECTION BRIDGE		ASSEMBLY SEGMENTS		DESCRIPTION	HEAD NUMBER				
	DEPOT	DIRECT SHIP					KNIFEHEAD		ASSEMBLY			PART NO.	QTY.	PART NO.	QTY.			PART NO.	QTY.	PART NO.	QTY.
							PART NO.	QTY.	PART NO.	QTY.											
BOLTED - 3" COARSE SECTIONS																					
47601030*	X	X	20 ft Split	80	87728905 84543491	XHVY-SS-BL XHVY-SM-BL HALF	84429101	9	87663841	145	84429102	—	—	47601019*	1	HEAD	84275285				
							84429100	4						84585645	1	CENTER					
							87663841	4						84585654	1	TAIL					
47601027*	X	X	25 ft Split	100	87728905 84543491	XHVY-SS-BL XHVY-SM-BL HALF	84429101	9	87663841	185	84429102	321848A1	16	47601016*	1	HEAD	84275285				
							84429100	4						84585645	1	CENTER					
							87663841	4						84585652	1	TAIL					
47601025*	X	X	30 ft Split	120	87728905 84543491	XHVY-SS-BL XHVY-SM-BL HALF	84429101	9	87663841	225	84429102	321848A1	32	47601016*	1	HEAD	84275285				
							84429100	4						84585645	1	CENTER					
							87663841	4						84585650	1	TAIL					
47601042*	X	X	30 ft LH Split	58	87728905 87470187 87470188	XHVY-SS-BL XHVY-SS-BL-TOP CTSK XHVY-SS-BL-SS CTSK-TOMHWK	84429101	9	87663841	99	84429102	—	—	47601019*	1	HEAD	84275285				
							84429100	4						87470018	7	84585661		1	CENTER		
							87663841	4						84585647	1	SPLICE KIT					
47601041*	X	X	30 ft RH Split	57	87728905 87470186	XHVY-SS-BL XHVY-SS-BL-BOT CTSK	84429101	9	87663841	92	84429102	—	—	47601021*	1	HEAD	84275285				
							84429100	4						84429100	5	84585660		1	TAIL		
							87663841	4						87470018	6	84585647		1	SPLICE KIT		
47601023*	X	X	35 ft Split	140	87728905 84543491	XHVY-SS-BL XHVY-SM-BL HALF	84429101	9	87663841	265	—	321848A1	48	47601016*	1	HEAD	84275285				
							84429100	4						84585643	1	CENTER					
							87663841	4						84585645	2	CENTER					
47601044*	X	X	35 ft LH Split	68	87728905 87470187 87470188	XHVY-SS-BL XHVY-SS-BL-TOP CTSK XHVY-SS-BL-SS CTSK-TOMHWK	84429101	9	87663841	119	—	—	—	47601019*	1	HEAD	84275285				
							84429100	4						87470018	7	84585645		1	CENTER		
							87663841	4						84585663	1	TAIL					
47601043*	X	X	35 ft RH Split	67	87728905 87470186	XHVY-SS-BL XHVY-SS-BL-BOT CTSK	84429101	9	87663841	112	—	—	—	47601021*	1	HEAD	84275285				
							84429100	4						84429100	5	84585662		1	TAIL		
							87663841	4						87470018	6	84585647		1	SPLICE KIT		
BOLTED - 3" FINE SECTIONS																					
47601031*	X	X	20 ft Split	80	87728899 84543491	XHVY-TS-BL XHVY-SM-BL HALF	84429101	9	87663841	145	84429102	—	—	47601020*	1	HEAD	84275285				
							84429100	4						84585646	1	CENTER					
							87663841	4						84585655	1	TAIL					
47601029*	X	X	25 ft Split	100	87728899 84543491	XHVY-TS-BL XHVY-SM-BL HALF	84429101	9	87663841	185	84429102	321848A1	16	47601017*	1	HEAD	84275285				
							84429100	4						84585646	1	CENTER					
							87663841	4						84585653	1	TAIL					
47601026*	X	X	30 ft Split	120	87728899 84543491	XHVY-TS-BL XHVY-SM-BL HALF	84429101	9	87663841	225	84429102	321848A1	32	47601017*	1	HEAD	84275285				
							84429100	4						84585644	1	CENTER					
							87663841	4						84585646	1	CENTER					
47601040*	X	X	30 ft LH Split	58	87728899 84467292 87470188	XHVY-SS-BL XHVY-SS-BL-TOP CTSK XHVY-SS-BL-SS CTSK-TOMHWK	84429101	9	87663841	99	84429102	—	—	47601020*	1	HEAD	84275285				
							84429100	4						84585659	1	CENTER					
							87663841	4						87470018	7	84585647		1	SPLICE KIT		
47601038*	X	X	30 ft RH Split	57	87728899 84467282	XHVY-TS-BL XHVY-SS-BL-BOT CTSK	84429101	9	87663841	92	84429102	—	—	47601022*	1	HEAD	84275285				
							84429100	4						84429100	5	84585646		1	TAIL		
							87663841	4						87470018	6	84585647		1	SPLICE KIT		
47601024*	X	X	35 ft Split	140	87728899 84543491	XHVY-TS-BL XHVY-SM-BL HALF	84429101	9	87663841	265	—	321848A1	48	47601017*	1	HEAD	84275285				
							84429100	4						84585644	1	CENTER					
							87663841	4						84585646	2	CENTER					
47601034*	X	X	35 ft LH Split	68	87728899 84467292 87470188	XHVY-SS-BL XHVY-SS-BL-TOP CTSK XHVY-SS-BL-SS CTSK-TOMHWK	84429101	9	87663841	119	—	—	—	47601020*	1	HEAD	84275285				
							84429100	4						84429100	5	84585657		1	TAIL		
							87663841	4						87470018	7	84585647		2	SPLICE KIT		
47601032*	X	X	35 ft RH Split	67	87728899 84467282	XHVY-TS-BL XHVY-SS-BL-BOT CTSK	84429101	9	87663841	112	—	—	—	47601022*	1	HEAD	84275285				
							84429100	4						84429100	5	84585656		1	TAIL		
							87663841	4						87470018	6	84585647		1	SPLICE KIT		

*Connector block for sickles and head segments need to be purchased separately from MY 2013 PN 84275917 to MY 2014 PN 47390299.

KNIFE ASSEMBLIES – CASE IH

2010 & 2020 HEADERS – 3" SYSTEM FOR COMBINES

KNIFE ASSEMBLY	AVAILABILITY		PLAT-FORM LENGTH	NUMBER OF KNIFE SECTIONS	KNIFE SECTION	TYPE OF SECTION	FASTENERS				FASTENER LOCKNUT (IF REQ.)	KNIFE CLIPS				HEAD NUMBER		
	DEPOT	DIRECT SHIP					KNIFEHEAD		ASSEMBLY			PART NO.	QTY.	KNIFEHEAD			ASSEMBLY	
							PART NO.	QTY.	PART NO.	QTY.				PART NO.	QTY.		PART NO.	QTY.
BOLTED – SUPER STA-SHARP																		
86900832 10 ft (LH)	X	X	20 ft	38 1	86616691 86616692	XHVY-SS-BL XHVY-SS-BL	1979166C1 86507778	5 4	86512289 86507777	5 67	848083	— —	— —	86630786 86630787	9 9	848094		
86900833 10 ft (RH) 86512289-6	X	X	20 ft	36 3	86616691 86616693	XHVY-SS-BL XHVY-SS-BL	1979166C1 86507778	5 4	86517390 86507777 86512289	5 58 6	848083	— — —	— — —	86630786 86630787	9 9	848094		
86900834 12.5 ft (LH)	X	X	25 ft	48 1	86616691 86616692	XHVY-SS-BL XHVY-SS-BL	1979166C1 86507778	5 4	86512289 86507777	5 87	848083	— —	— —	86630786 86630787	11 11	848094		
86900835 12.5 ft (RH) 86512289-6	X	X	25 ft	46 3	86616691 86616693	XHVY-SS-BL XHVY-SS-BL	1979166C1 86507778	5 4	86517390 86507777 86512289	5 78 6	848083	— — —	— — —	86630786 86630787	11 11	848094		
86977981 15 ft (LH)	X	X	30 ft	58 1	86616691 86616692	XHVY-SS-BL XHVY-SS-BL	1979166C1 86507778	5 4	86512289 86507777	5 107	848083	— —	— —	86630786 86630787	14 14	848094		
86977982 15 ft (RH) 86512289-6	X	X	30 ft	56 3	86616691 86616693	XHVY-SS-BL XHVY-SS-BL	1979166C1 86507778	5 4	86517390 86507777 86512289	5 98 6	848083	— — —	— — —	86630786 86630787	14 14	848094		

1010 & 1020 HEADERS – 3" SYSTEM, KNIVES FOR COMBINES

See High Shoulder Sections Page 48.

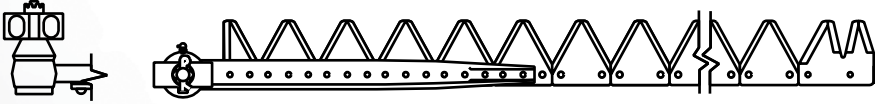

KNIFE ASSEMBLY	AVAILABILITY		PLAT-FORM LENGTH	NUMBER OF KNIFE SECTIONS	KNIFE SECTION	TYPE OF SECTION	FASTENERS				FASTENER LOCKNUT (IF REQ.)	KNIFE CLIPS				HEAD NUMBER		
	DEPOT	DIRECT SHIP					KNIFEHEAD		ASSEMBLY			PART NO.	QTY.	KNIFEHEAD			ASSEMBLY	
							PART NO.	QTY.	PART NO.	QTY.				PART NO.	QTY.		PART NO.	QTY.
HIGH SHOULDER BOLTED																		
451830A2*	X	—	15 ft	58	436995A1	XHVY-TS-BL	1979166C1-13 87027493-3	16	86507777	101	848083	—	—	1307280C3	14	1316161C95		
451831A2*	X	—	17.5 ft	68	436995A1	XHVY-TS-BL	1979166C1-13 87027493-3	16	86507777	113	848083	—	—	1307280C3	16	1316161C95		
451832A2*	X	—	20 ft	78	436995A1	XHVY-TS-BL	1979166C1-13 87027493-3	16	86507777	133	848083	—	—	1307280C3	19	1316161C95		
451833A2*	X	—	22.5 ft	88	436995A1	XHVY-TS-BL	1979166C1-13 87027493-3	16	86507777	153	848083	—	—	1307280C3	21	1316161C95		
451828A3	X	—	25 ft	98	436995A1	XHVY-TS-BL	1979166C1-13 87027493-3	16	87423458-74 87027493-3	109 80	848083	—	—	1307280C3	24	1316161C95		
451829A3	X	—	30 ft	118	436995A1	XHVY-TS-BL	1979166C1-13 87027493-3	16	86507777 700715170	129 80	848083	—	—	1307280C3	29	1316161C95		
BOLTED																		
87439540E	—	**	15 ft	58	112074A1	XHVY-SS-BL	1979166C1	16	86507777	109	848083	—	—	1307280C3	14	1316161C95		
87439541E	—	**	16.5 ft	64	112074A1	XHVY-SS-BL	1979166C1	16	86507777	121	848083	—	—	1307280C3	15	1316161C95		
87439542E	—	**	17.5 ft	68	112074A1	XHVY-SS-BL	1979166C1	16	86507777	129	848083	—	—	1307280C3	16	1316161C95		
87439543E	—	**	20 ft	78	112074A1	XHVY-SS-BL	1979166C1	16	86507777	149	848083	—	—	1307280C3	19	1316161C95		
87439544E	—	**	22.5 ft	88	112074A1	XHVY-SS-BL	1979166C1	16	86507777	169	848083	—	—	1307280C3	21	1316161C95		

* Segmented Assemblies

** Available on the Product Support Program

KNIFE ASSEMBLIES – CASE IH

1010 & 1020 HEADERS – 3" SPLIT KNIFE SYSTEM FOR COMBINES

Knifehead included in Head Segment. Order Split Knife Assembly part number and receive all segments in one bundle, or order individual segments as shown.

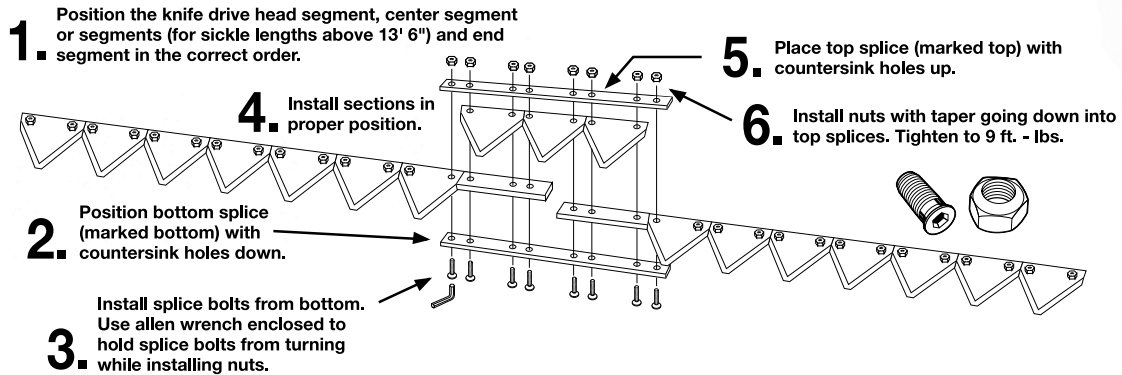

SPLIT KNIFE ASSEMBLY	AVAILABILITY		LENGTH	TYPE KNIFE SECTIONS	HEAD OF SECTION	HEAD SEGMENT PART NO.	HEAD SEGMENT QTY.	CENTER SEGMENT PART NO.	CENTER SEGMENT QTY.	TAIL SEGMENT PART NO.	TAIL SEGMENT QTY.	SPLIT KIT PART NO.	KIT QTY.
	DEPOT	DIRECT SHIP											
BOLTED													
451830A2	X	—	15 ft	436995A1	XHVY-TS-BL	—	1	—	—	—	1	371658A1	1
451831A2	X	—	17.5 ft	436995A1	XHVY-TS-BL	—	1	—	1	—	1	371658A1	2
451832A2	X	—	20 ft	436995A1	XHVY-TS-BL	—	1	—	1	—	1	371658A1	2
451833A2	X	—	22.5 ft	436995A1	XHVY-TS-BL	—	1	—	1	—	1	371658A1	2
451834A3	X	X	25 ft	436995A1	XHVY-TS-BL	451839A2	1	—	1	371632A1	1	371658A1	2
451835A3	X	X	30 ft	436995A1	XHVY-TS-BL	451839A2	1	—	2	371636A1	1	371658A1	3
BOLTED – STA-SHARP													
371613A2	X	X	15 ft	112074A1	XHVY-SS-BL	371638A2	1	—	—	—	1	371658A1	1
371617A2	X	X	16.5 ft	112074A1	XHVY-SS-BL	371638A2	1	—	—	371650A1	1	371658A1	1
371618A2	X	X	17.5 ft	112074A1	XHVY-SS-BL	371638A2	1	371643A1	1	371646A1	1	371658A1	2
371619A2	X	X	20 ft	112074A1	XHVY-SS-BL	371638A2	1	371643A1	1	371647A1	1	371658A1	2
371620A2	X	X	22.5 ft	112074A1	XHVY-SS-BL	371638A2	1	371643A1	1	371649A1	1	371658A1	2
371621A3	X	X	25 ft	112074A1	XHVY-SS-BL	371642A3	1	371644A2*	1	371650A1	1	371658A1	2
371622A3	X	X	30 ft	112074A1	XHVY-SS-BL	371642A3	1	371643A1 & 371644A2*	2	371652A1	1	371658A1	3
BOLTED – STA-SHARP WITH PLATED SECTIONS													
B96615	—	X	25 ft	191256A1	XHVY-SS-PL	—	1	—	1	—	1	371658A1	2
B96616	—	X	30 ft	191256A1	XHVY-SS-PL	—	1	—	2	—	1	371658A1	3

*With Section Reinforcing Straps.

Note: Order both center segments for 30 ft assembly.

- Split knives reduce the potential for freight damage due to their shorter lengths.
- Split knives increase the ease of shipments by using small package carriers.
- Split knives can be assembled in the field in an average of 20 minutes, offsetting the amount of time it takes to strap a one piece knife to your vehicle.

KNIFE ASSEMBLIES – CASE IH

1010 & 1020 1-1/2" SYSTEM

One-Piece Knives with Improved, Stronger Sections for Combines

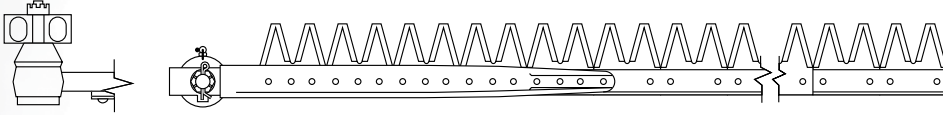

KNIFE ASSEMBLY	AVAILABILITY		PLAT-FORM LENGTH	NUMBER OF KNIFE SECTIONS	KNIFE SECTION	TYPE OF SECTION	FASTENERS				FASTENER LOCKNUT (IF REQ.)	KNIFE CLIPS				HEAD NUMBER
	DEPOT	DIRECT SHIP					KNIFEHEAD		ASSEMBLY			KNIFEHEAD		ASSEMBLY		
							PART NO.	QTY.	PART NO.	QTY.		PART NO.	QTY.	PART NO.	QTY.	
AUSTEMPERED – BOLTED – STA-SHARP																
398746A1	X	—	15 ft	60	394618A1	XHVV-SS-BL	1970506C1	16	1970505C1	109	1970507C2	B92983	1	101001A2	26	1313795C95
398747A2	X	—	16.5 ft	66	394618A1	XHVV-SS-BL	1970506C1	16	1970505C1	121	1970507C2	B92983	1	101001A2	30	1313795C95
398748A2	X	—	17.5 ft	70	394618A1	XHVV-SS-BL	1970506C1	16	1970505C1	129	1970507C2	B92983	1	101001A2	32	1313795C95
398749A2	X	—	20 ft	80	394618A1	XHVV-SS-BL	1970506C1	16	1970505C1	149	1970507C2	B92983	1	101001A2	36	1313795C95
398750A2	X	—	22.5 ft	90	394618A1	XHVV-SS-BL	1970506C1	16	1970505C1	169	1970507C2	B92983	1	101001A2	42	1313795C95
398751A2	X	—	25 ft	100	394618A1	XHVV-SS-BL	1970506C1	16	1970505C1	189	1970507C2	B92983	1	101001A2	46	1313795C95
398752A2	X	—	30 ft	120	394618A1	XHVV-SS-BL	1970506C1	16	1970505C1	229	1970507C2	B92983	1	101001A2	56	1313795C95
BOLTED																
1970502C5	X	—	15 ft	60	1970390C4	XHVV-TS-BL	1970506C1	16	1970505C1	109	1970507C2	B92983	1	101001A2	26	1313795C95
1970503C5	X	—	16.5 ft	66	1970390C4	XHVV-TS-BL	1970506C1	16	1970505C1	121	1970507C2	B92983	1	101001A2	30	1313795C95
1970504C6	X	—	17.5 ft	70	1970390C4	XHVV-TS-BL	1970506C1	16	1970505C1	129	1970507C2	B92983	1	101001A2	32	1313795C95
1970400C6	X	—	20 ft	80	1970390C4	XHVV-TS-BL	1970506C1	16	1970505C1	149	1970507C2	B92983	1	101001A2	36	1313795C95
1970442C5	X	—	22.5 ft	90	1970390C4	XHVV-TS-BL	1970506C1	16	1970505C1	169	1970507C2	B92983	1	101001A2	42	1313795C95
1970402C5	X	—	25 ft	100	1970390C4	XHVV-TS-BL	1970506C1	16	1970505C1	189	1970507C2	B92983	1	101001A2	46	1313795C95
1970404C5	X	—	30 ft	120	1970390C4	XHVV-TS-BL	1970506C1	16	1970505C1	229	1970507C2	B92983	1	101001A2	56	1313795C95
BOLTED – STA-SHARP																
B93638	—	X	20 ft	80	B93329B	XHVV-SS-BL	1970506C1	16	1970505C1	149	1970507C2	B92983	1	101001A2	36	1313795C95
B93640	—	X	25 ft	100	B93329B	XHVV-SS-BL	1970506C1	16	1970505C1	189	1970507C2	B92983	1	101001A2	46	1313795C95

Note: All Knifeheads require locknut PN 848083.

820 HEADERS (FLEX)

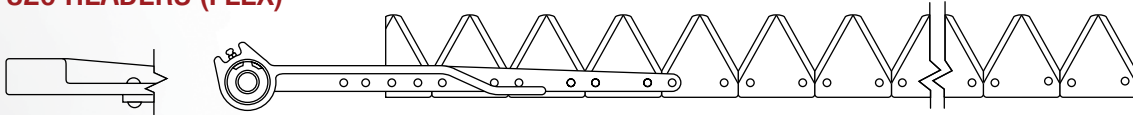

KNIFE ASSEMBLY	AVAILABILITY		PLAT-FORM LENGTH	NUMBER OF KNIFE SECTIONS	KNIFE SECTION	TYPE OF SECTION	FASTENERS				FASTENER LOCKNUT (IF REQ.)	KNIFE CLIPS				HEAD NUMBER
	DEPOT	DIRECT SHIP					KNIFEHEAD		ASSEMBLY			KNIFEHEAD		ASSEMBLY		
							PART NO.	QTY.	PART NO.	QTY.		PART NO.	QTY.	PART NO.	QTY.	
BOLTED																
ZAK197463	—	X	15 ft	55 3	826720C3 823713C3	XHVV-TS-BL XHVV-TS-PL	86507778	1	86507777	109	848083	84389554	1	B91963	14	B93244
ZAK197466	—	X	20 ft	75 3	826720C3 823713C3	XHVV-TS-BL XHVV-TS-PL	86507778	1	86507777	149	848083	84389554	1	B91963	19	B93244
RIVETED																
197462C93	X	—	13 ft	47 3	826720C3 823713C3	XHVV-TS-BL XHVV-TS-PL	990719R91	9 1	46436	93	—	611759R1	1	1307280C3	12	197230C91
197463C93	X	—	15 ft	55 3	826720C3 823713C3	XHVV-TS-BL XHVV-TS-PL	990719R91 B91970	9 1	46436	109	—	611759R1	1	1307280C3	14	197230C91
197464C93	X	—	16.5 ft	61 3	826720C3 823713C3	XHVV-TS-BL XHVV-TS-PL	990719R91	9 1	46436	121	—	611759R1	1	1307280C3	15	197230C91
197465C93	X	—	17.5 ft	65 3	826720C3 823713C3	XHVV-TS-BL XHVV-TS-PL	990719R91	9 1	46436	129	—	611759R1	1	1307280C3	16	197230C91
197466C93	X	—	20 ft	75 3	826720C3 823713C3	XHVV-TS-BL XHVV-TS-PL	990719R91 B91970	9 1	46436	149	—	611759R1	1	1307280C3	19	197230C91

KNIFE ASSEMBLIES – CASE IH

810 & 820 HEADER (500 CPM) – NON FLOAT FOR COMBINES

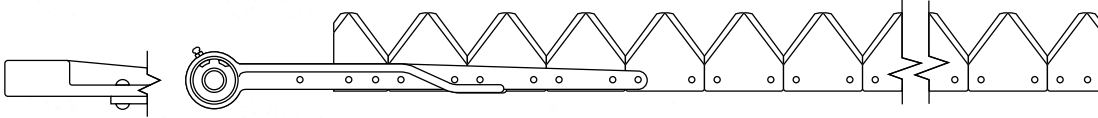

KNIFE ASSEMBLY	AVAILABILITY		PLAT-FORM LENGTH	NUMBER OF KNIFE SECTIONS	KNIFE SECTION	TYPE OF SECTION	FASTENERS				FASTENER LOCKNUT (IF REQ.)	KNIFE CLIPS				HEAD NUMBER
	DEPOT	DIRECT SHIP					KNIFEHEAD		ASSEMBLY			KNIFEHEAD		ASSEMBLY		
							PART NO.	QTY.	PART NO.	QTY.		PART NO.	QTY.	PART NO.	QTY.	
BOLTED																
ZAK176720	—	X	20 ft	75 3	634794R3 634788R3	XHVV-TS-PL XHVV-TS-PL	86507778	1	86507777	151	848083	—	—	B91963	19	178466C91
RIVETED																
197183C93	X	—	16.5 ft	61 3	634793R3 634788R3	XHVV-TS-BL XHVV-TS-PL			46436	123	—	—	—	176722C1	15	178466C91
176696C93	X	—	20 ft	75 3	634793R3 634788R3	XHVV-TS-BL XHVV-TS-PL			46436	151	—	—	—	176722C1	19	178466C91
176697C93	X	—	24 ft	91 3	634793R3 634788R3	XHVV-TS-BL XHVV-TS-PL			46436	183	—	—	—	176722C1	23	178466C91
176721C93	X	—	24 ft	91 3	634794R3 634788R3	XHVV-TS-PL XHVV-TS-PL			46436	183	—	—	—	176722C1	23	178466C91
187418C93	X	—	30 ft	115 3	634794R3 634788R3	XHVV-TS-PL XHVV-TS-PL			46436	231	—	—	—	176722C1	29	178466C91

810 HEADER (600 CPM) – NON FLOAT FOR COMBINES

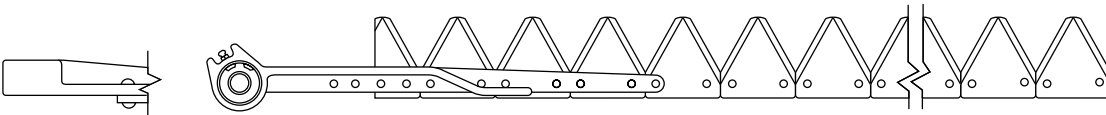

KNIFE ASSEMBLY	AVAILABILITY		PLAT-FORM LENGTH	NUMBER OF KNIFE SECTIONS	KNIFE SECTION	TYPE OF SECTION	FASTENERS				FASTENER LOCKNUT (IF REQ.)	KNIFE CLIPS				HEAD NUMBER
	DEPOT	DIRECT SHIP					KNIFEHEAD		ASSEMBLY			KNIFEHEAD		ASSEMBLY		
							PART NO.	QTY.	PART NO.	QTY.		PART NO.	QTY.	PART NO.	QTY.	
BOLTED																
ZAK1308217	—	X	24 ft	91 3	634794R3 634788R3	XHVV-TS-PL XHVV-TS-PL	86507778	1	86507777	183	848083	84389554	1	84389548	23	197230C91
RIVETED																
1308217C92	X	—	24 ft	91 3	634794R3 634788R3	XHVV-TS-PL XHVV-TS-PL			46436	183	—	—	1	176722C1	23	197230C91

DISC MOWER KNIVES

MOWER-CONDITIONERS

HAY MACHINES

WINDROWERS

COMBINES

HARDWARE/PARTS

SHAPES CHARTS

KNIFE ASSEMBLIES – CASE IH

1042 & 1052 DRAPER HEADERS

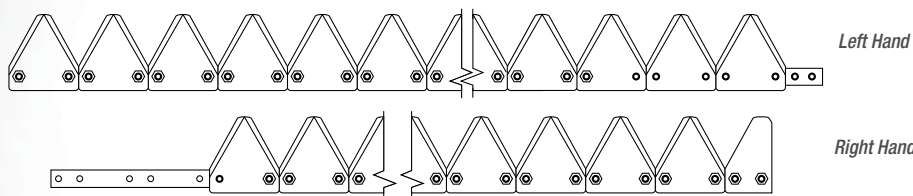

KNIFE ASSEMBLY	AVAILABILITY		PLAT-FORM LENGTH	NUMBER OF KNIFE SECTIONS	KNIFE SECTION	TYPE OF SECTION	FASTENERS				FASTENER LOCKNUT (IF REQ.)	KNIFE CLIPS				HEAD NUMBER
	DEPOT	DIRECT SHIP					KNIFEHEAD		ASSEMBLY			KNIFEHEAD		ASSEMBLY		
							PART NO.	QTY.	PART NO.	QTY.		PART NO.	QTY.	PART NO.	QTY.	
BOLTED – COARSE SECTIONS																
87456670 21 ft (LH)	X	—	21 ft	83	345890A1	XHVY TS BL	1979166C1 395823A1	7 12	86507777	154	848083	—	—	84399893	—	395823A1
87457982 4 ft (RH)	X	—	4 ft	15 1	345890A1 1327411C1	XHVY TS BL	—	—	86507777 86507778	27 6	848083	—	—	84399893	—	—
87422088	X	—	9 ft	35 1	345890A1 1327411C1	XHVY TS BL	—	—	86507777 86507778	67 6	848083	—	—	84399893	—	—
87422089	X	—	15 ft	57 1	345890A1 1327411C1	—	—	—	86507777	115	848083	—	—	84399893	—	—
87456669 21 ft (RH)	X	—	21 ft	83	1327448C1	XHVY TS BL	1979166C1 86507778	7 12	86507777	148	848083	—	—	84399893	—	395823A1
381137A1	X	—	4 ft	15 1	1327448C1 1327411C1	XHVY TS BL	—	—	86507777 86507778	27 6	848083	—	—	84399893	—	—
131482A1 9 ft (RH)	X	—	9 ft	33 1	1327448C1 1327411C1	XHVY TS BL	—	—	86507777	67	848083	—	—	84399893	—	—
126689A1 15 ft (RH)	X	—	15 ft	57 1	1327448C1 1327411C1	XHVY TS BL	—	—	86507777	115	848083	—	—	84399893	—	—

Use 126622A2 Splice Kit for assembly



QUALITY CUTTING PARTS FOR OTHER BRANDS

DISC MOWER KNIVES

MOWER-CONDITIONERS

HAY MACHINES

WINDROWERS

COMBINES

HARDWARE/PARTS

SHAPES CHARTS

SECTIONS FOR COMBINE HEADERS – VARIOUS BRANDS



CASE IH PART NO.	DEPOT	DIRECT SHIP	THICKNESS	FASTENER SIZE	NUMBER OF HOLES	FINISH	TYPE OF SECTION	PACKAGE QUANTITY	ORDER MULTIPLE	REPLACEMENT FOR	SPECIFIC MODEL OR APPLICATION
SCHUMACHER											
B95013P	—	X	HVY	6mm	2	Black	TS	10	10	420-100-047	14 serration SCH replacement section

All part numbers shown on this page represent a merchandise pack of 10 sections. With an order multiple of 10, you receive 100 sections (10 packs of 10).

KITS

1010 & 1020 COMBINE KNIFEHEAD/KNIFEBACK REINFORCEMENT KIT

(For 3" Knife Systems Only)

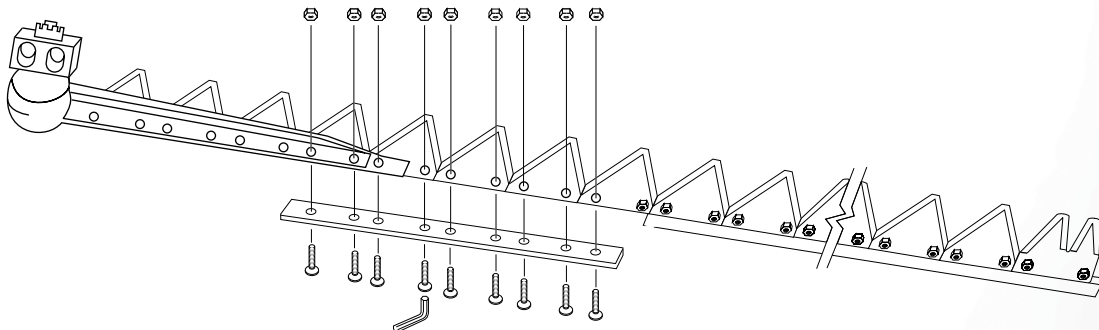

CASE IH PART NO.	DEPOT	DIRECT SHIP	DESCRIPTION	KIT CONTENTS
227213A1	X	—	Heat Treated Reinforcement Strap Kit	1 instruction card 1 heat treated reinforcement bar w 60 degree ctsk holes (#227455A1) 9 locking cone nuts 12/24 (#848083) 1 allen wrench 3 ctsk bolts 1-1/4" long X 12/24 (#227456A1) 6 ctsk bolts 3/4" long X 12/24 (#227457A1)

KITS

STANDARD SINGLE POINT SECTIONS – COMBINES WITH 3" CUT SYSTEMS

High Shoulder Sections – The new high shoulder section is designed to reduce plugging in the cutter bar, while also reducing shatter loss.



CASE IH PART NO.	DEPOT	DIRECT SHIP	THICKNESS	FASTENER SIZE	NUMBER OF HOLES	FINISH	TYPE OF SECTION	PACKAGE QUANTITY	DEPOT ORDER MULTIPLE	DIRECT SHIP ORDER MULTIPLE
126749A1	X	—	Regular	7/32"	2	Black	TS	25	25	—
179736C3	X	—	XHVV	7/32"	2	Plated	TS	25	25	—
634793R3	X	X	XHVV	7/32"	2	Black	TS	25	25	25
634788R3	X	X	XHVV	1/4"	2	Plated	TS	25	25	25
634794R3	X	X	XHVV	7/32"	2	Plated	TS	25	25	25
826720C3	X	X	XHVV	7/32"	3	Black	TS	25	25	25
436995A1	X	—	XHVV	7/32"	3	Black	TS	25	25	—
112074P	—	X	XHVV	7/32"	3	Black	SS	10	10	10
112074H	—	X	XHVV	7/32"	3	Black	SS	—	—	100
112074A1	X	X	XHVV	7/32"	3	Black	SS	25	25	25

1) "P" suffix part numbers shown on this page represent a merchandise pack of 10 sections. With an order multiple of 10, you receive 100 sections (10 packs of 10).

2) "H" suffix part numbers shown on this page are priced and ordered per section. With an order multiple of 100, you receive 100 sections (Bulk Packed).

3) All other part numbers available from the Depot are order multiples of the package quantity as shown.

TWO POINTED SECTIONS – COMBINES WITH 1-1/2" CUT SYSTEMS



CASE IH PART NO.	DEPOT	DIRECT SHIP	THICKNESS	FASTENER SIZE	NUMBER OF HOLES	FINISH	TYPE OF SECTION	PACKAGE QUANTITY	DEPOT ORDER MULTIPLE	DIRECT SHIP ORDER MULTIPLE
394618A1	X	X	XHVV	7/32"	3 RND	Black	TS	25	25	25
1970390C4	X	X	XHVV	7/32"	3 OVAL	Black	TS	100	25	25
B93329P	—	X	XHVV	7/32"	3 OVAL	Black	SS	10	—	10
B93329B	X	X	XHVV	7/32"	3 OVAL	Black	SS	25	25	25
B93329H	—	X	XHVV	7/32"	3 OVAL	Black	SS	25	—	100
B93330P	—	X	XHVV	7/32"	3 OVAL	Plated	SS	10	—	10
B93330B	X	X	XHVV	7/32"	3 OVAL	Plated	SS	25	25	25

1) "P" suffix part numbers shown on this page represent a merchandise pack of 10 sections. With an order multiple of 10, you receive 100 sections (10 packs of 10).

2) "B" suffix part numbers shown on this page are priced and ordered per section. With an order multiple of 100, you receive 100 sections (4 packs of 25).

3) "H" suffix part numbers shown on this page are priced and ordered per section. With an order multiple of 100, you receive 100 sections (Bulk Packed).

4) All other part numbers available from the Depot are order multiples of the package quantity as shown.

END SECTIONS – HAY MACHINES & COMBINES

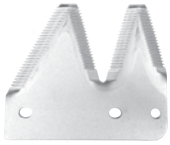

CASE IH PART NO.	DEPOT	DIRECT SHIP	THICKNESS	SIDE USED	FASTENER SIZE	NUMBER OF HOLES	FINISH	TYPE OF SECTION	PACKAGE QUANTITY	DEPOT ORDER MULTIPLE	DIRECT SHIP ORDER MULTIPLE
748145	X	—	XHVV	LH	7/32"	2 Rnd	Plated	TS	1	1	—
700705463	X	X	XHVV	RH	7/32"	3 Rnd	Black	TS	5	50	5
86617760	X	X	XHVV	RH	7/32"	3 Rnd	Plated	TS	5	50	5
700705462	X	X	XHVV	LH	7/32"	3 Rnd	Plated	TS	5	50	5
ZA290658	X	—	XHVV	RH	7/32"	2 Slots	Plated	Smooth	5	50	—
86617759	X	X	XHVV	LH	7/32"	3 Rnd	Black	TS	5	50	5
86617760	X	X	XHVV	RH	7/32"	3 Rnd	Black	TS	5	50	5
324070A1	X	—	XHVV	RH	7/32"	3 Rnd	Black	TS	5	5	—
B92387*	—	X	XHVV	RH	7/32"	3 Rnd	Black	TS	1	1	15
B92388*	—	X	XHVV	LH	7/32"	3 Rnd	Black	TS	1	1	15
86616976*	X	X	XHVV	RH	7/32"	3 Rnd	Black	TS	1	15	1

*Refers to End Section Kits

HALF SECTIONS – HAY MACHINES & COMBINES



CASE IH PART NO.	DEPOT	DIRECT SHIP	THICKNESS	SIDE USED	FASTENER SIZE	NUMBER OF HOLES	FINISH	TYPE OF SECTION	PACKAGE QUANTITY	ORDER MULTIPLE
1316030C2	X	—	XHVV	LH	7/32"	2	Black	Blank	5	5
559269R2	X	—	REG	LH	7/32"	2	Black	TS	10	10
1319392C2	X	—	XHVV	LH	7/32"	2	Black	Smooth	5	5
ZA502643	X	—	XHVV	RH	7/32"	2	Plated	Blank	1	1
48868	X	—	REG	RH	7/32"	2	Plated	Smooth	10	10

3020 SECTIONS WITH METRIC HARDWARE

KNIFE SECTION	TYPE OF SECTION
87728905	XHVV-SS-BL
87470186	XHVV-SS-BL-BTM CTSK
87470187	XHVV-SS-BL-TOP CTSK
87728899	XHVV-TS-BL
84467282	XHVV-TS-BL-BTM CTSK
84467292	XHVV-TS-BL-TOP CTSK

METRIC HARDWARE

PART NUMBER	DESCRIPTION	CONTAINS		DESCRIPTION
		PART NO.	QTY.	
73342915	Metric Sickle - Standard Hardware	87663841	50	M6 × 18mm Bolt
		84429102	50	M6 Nut
73342916	Metric Sickle - Auger Header Hardware Kit	84429101	9	M6 × 28mm Bolt
		84429100	4	M6 × 22mm Bolt
73342917	Metric Sickle - Draper Header Hardware Kit (15.36 mm)	84429102	10	M6 Nut
		87470018	10	M6 × 15.36mm Bolt
73342918	Metric Sickle - Draper Header Hardware Kit (22 mm)	84429100	10	M6 × 22mm Bolt
		84429102	10	M6 Nut

DISC MOWER KNIVES

MOWER-CONDITIONERS

HAY MACHINES

WINDROWERS

COMBINES

HARDWARE/PARTS

SHAPES CHARTS

HARDWARE/REPLACEMENT PARTS

HARDWARE/ REPLACEMENT PARTS

- 51** SECTION REINFORCING STRAP KIT
- 51** REPLACEMENT SPLICE/REPAIR KITS FOR SPLIT KNIFE ASSEMBLIES
- 51** RECOMMENDED INSTRUCTIONS TO REPAIR A BROKEN SICKLE
- 52** KNIFE CLIPS – CASE IH APPLICATIONS
- 53** CARDED KNIFE CLIPS – UNIVERSAL APPLICATIONS
- 53** BOXED KNIFE CLIPS – UNIVERSAL APPLICATIONS
- 53** 2' REPAIR KIT
- 54** OVAL HEAD RIVETS FOR STANDARD RIVETED ASSEMBLIES
- 54** COUNTERSUNK RIVETS FOR RIVETED ASSEMBLIES WITH KNIFEBACK ON TOP OF SECTION
- 54** PAN HEAD RIVETS USED IN KNIFEHEADS ON RIVETED ASSEMBLIES FOR 1190, 1290, 1490 & 1590 PLATFORMS
- 55** OVAL HEAD BOLTS FOR STANDARD BOLTED KNIFE ASSEMBLIES
- 55** 60° COUNTERSUNK BOLTS FOR KNIFE ASSEMBLIES WITH KNIFEBACK ON TOP OF SECTIONS, OR WITH COUNTERSUNK SECTIONS
- 56** 82° COUNTERSUNK BOLTS TWIN SICKLE BOLTED ASSEMBLIES
- 56** OVAL SHOULDER BOLTS FOR CASE IH 1010 & 1020 1-1/2" CUT PLATFORMS
- 56** LOCK NUTS AND JAM NUTS FOR BOLTED KNIFE ASSEMBLIES
- 57** WEARPLATES FOR CASE IH AND UNIVERSAL APPLICATIONS
- 57** KNIFEHEAD PIN REPLACEMENT KIT FOR CASE IH BALANCED HEAD MOWERS

SECTION REINFORCING STRAP KIT



CASE IH PART NO.	DEPOT	DIRECT SHIP	DESCRIPTION	KIT CONTENTS
321849A2	—	X	Section reinforcing strap and hardware kit	100 Nuts, 100 Bolts and 50 Straps
321848A1	X	—	Section reinforcing straps	25 pcs.

REPLACEMENT SPLICE/REPAIR KITS FOR SPLIT KNIFE ASSEMBLIES

(For 3" Knife Systems Only)



CASE IH PART NO.	DEPOT	DIRECT SHIP	DESCRIPTION	KIT CONTENTS
371658A1	X	X	Splice Kit for assemblies with 2-1/16" hole spacing for Case IH application	1 instruction card 1 allen wrench Hardware
B92973	X	X	Splice Kit for assemblies with 2-1/8" hole spacing	1 instruction card 1 allen wrench Hardware
84585647	X	X	Splice Kit for assemblies with 2-1/16" hole spacing metric hardware	1 instruction card 1 allen wrench Hardware

Note: Not for use on 810 Case Headers or any knife assembly with knifeback on top of section.
Air tools are not recommended for assembly of splice kit.

FOLLOW THESE RECOMMENDED INSTRUCTIONS TO REPAIR A BROKEN SICKLE

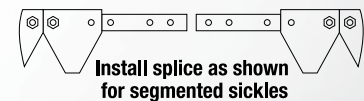
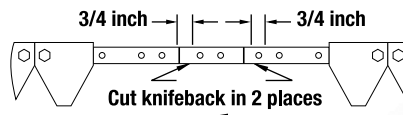
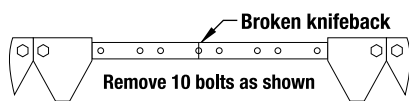

Split Kit will mend most broken sickles. Breaks near the head of the sickle can be moved to the tail end with Split Kit. Some drilling may be required to mount the knifehead in new positions.

HARDWARE/REPLACEMENT PARTS

KITS

KNIFE CLIPS – CASE IH APPLICATIONS

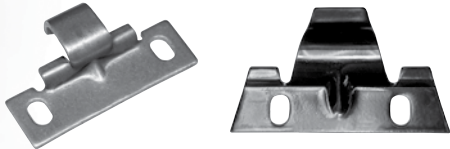

CASE IH PART NO.	DEPOT	DIRECT SHIP	DESCRIPTION	APPLICATION	PACKAGE QUANTITY	ORDER MULTIPLE
179757C1	X	—	Assembly Clip (Bolted or Riveted)	810, 820 Floating Headers	1	1
180480C1	X	—	Knifehead Clip (Bolted or Riveted)	810, 820 Floating Headers	1	1
112428A1	X	—	Knifehead Clip (Bolted) Optional	1010/1020 – 1-1/2"	1	1
611759R1	X	—	Knifehead Clip (Riveted) Replaces MB812	Balanced Head Mowers, 816 Mower Conditioner 990 Mower Conditioner, 1190 Mower Conditioner 1490 Mower Conditioner, 1590 Mower Conditioner 810 Grain Header, 820 Flex Combine Header	1	1
MA812	X	—	Assembly Clip (Riveted)	Ball type Head Mowers, Balanced Head Mowers, 816 Mower Conditioner	25	25
595648R1	X	—	Knifehead Clip (Riveted)	1290 Mower Conditioner, 275 Mower Conditioner, 375 Mower Conditioner	1	1
824981C1	X	—	Knifehead Clip (Riveted)	4000, 5000, 5500, Draper Header	1	1
613842R2	X	—	Assembly Clip (Bolted or Riveted)	1290 Mower Conditioner, 75 Windrower, 275 Mower Conditioner, 375 Mower Conditioner, 4000, 5000, 5500 Windrowers, 721, 725 Windrowers 730, 736 Windrowers, 742 Windrowers 750 Windrowers, 6000, 6500 Windrowers 8210, 8220, 8230, 8240 Draper Header, 810 Rigid Combine Header (600CPM), 8820, 8830, 8840 Draper Headers	1	1
142984	X	—	Knifehead Clip (Bolted or Riveted)	8320, 8330 Mower Conditioner, 8350 Mower Conditioner	1	1
700111204	X	—	Assembly Clip (Bolted or Riveted)	8210, 8220, 8230, 8240 Mower Conditioner 8320, 8330, 8340, 8350 Mower Conditioner	1	1
700109725	X	—	Adjustable Hold Down Clip (Bolted or Riveted) *Center Assembly Clip for SC414 DLX, SC416 DLX, and 625 Dual Auger Header	8340 Mower Conditioner, 8350 Mower Conditioner 8360, 8370 Mower Conditioner 8830 Mower Conditioner 8820, 8830, 8840 Auger Headers	1	1
176722C1	X	—	Assembly Clip (Riveted)	810, 820 Rigid 500 CPM Platforms	1	1
1307280C3	X	—	Assembly Clip (Bolted or Riveted)	820 Flex Combine Header 1010/1020 3 Cut Combine Header	10	10
101001A2	X	—	Assembly Clip (Bolted or Riveted)	1010/1020 1-1/2" System	5	5
84399893	X	—	Assembly Clip (Bolted)	1042, 1052 Draper Header	50	50
700134757	X	—	Assembly Clip (Bolted)	SC412, SC414, SC414 DLX, SC416 DLX, 525 Auger Header, 425 Shiftable Draper Header 625 Dual Auger Header	1	1
700134758	X	—	Assembly Clip (Bolted)	SC414 DLX, SC416 DLX, 625 Dual Auger Header	1	1
6832703	X	—	Center Assembly Clip (Bolted)	425 Shiftable Draper Header	1	1
700148847	X	—	Assembly Clip (Bolted)	425 Shiftable Draper Header	1	1
84389554	—	X	High Arch Knife Clip	Bolted Knife Heads	25	25
700148847	—	X	Center Clip	810/820 Bolted Knives	25	25

CARDED KNIFE CLIPS – UNIVERSAL APPLICATIONS

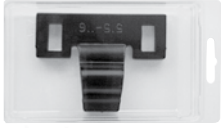

CASE IH PART NO.	DEPOT	DIRECT SHIP	DESCRIPTION	APPLICATION	CARD QUANTITY	ORDER MULTIPLE
B92393	—	X	Knifehead Clip (Riveted or Bolted) Steel	Universal Knifehead Clip - Hay or Combine	1	10
B93356	—	X	Assembly Clip (Bolted) Steel w/ 2 shims (.145 thick shims)	700 Series Case Windrowers	2	10

BOXED KNIFE CLIPS – UNIVERSAL APPLICATIONS



CASE IH PART NO.	DEPOT	DIRECT SHIP	DESCRIPTION	APPLICATION	PACKAGE QUANTITY	ORDER MULTIPLE
84389548	—	X	Assembly Clip (Riveted or Bolted) Steel	Universal Hay Clip	25	25
B91963	—	X	Assembly Clip (Riveted or Bolted) Steel	Universal Combine Clip	25	25
84389554	—	X	Knifehead Clip (Riveted or Bolted) Steel	Universal Knifehead Clip - Hay or Combine	25	25
84389553	—	X	Knifehead Clip (Riveted or Bolted) Steel	For all Versatile Machines	25	25

2' REPAIR KIT



CASE IH PART NO.	DEPOT	DIRECT SHIP	DESCRIPTION	KIT CONTENTS
B95005	—	X	2' Repair Kit	8 pcs. XH-TS-BL SSS sections (#112074A1) 16 pcs. 12/24 x 5/8" bolts (#86507777) 16 pcs. 12/24 cone nuts (#848083)

My Shed™ Mobile App 2.1

MANAGE YOUR EQUIPMENT
FROM YOUR SMARTPHONE.

SEE PAGE 2 FOR DETAILS.



Google Play™
for Android™



Apple® Store
for iPhone®



HARDWARE/REPLACEMENT PARTS

RIVETS

OVAL HEAD RIVETS FOR STANDARD RIVETED ASSEMBLIES



CASE IH PART NO.	DEPOT	DIRECT SHIP	DIAMETER	LENGTH	RIVET APPLICATION	PACKAGE QUANTITY	PACKAGE TYPE	ORDER MULTIPLE
990817R91	X	—	#5-1/2 (7/32")	9/16"	HVY Sections	1 lb	Bag	1
84389555	—	X	#5-1/2 (7/32")	9/16"	HVY Sections	1 lb	Plastic Box	10
1980897C1	X	—	#5-1/2 (7/32")	5/8"	XHVY Sections	1 lb	Bag	1
B91969	—	X	#5-1/2 (7/32")	5/8"	XHVY Sections	1 lb	Plastic Box	10
990719R91	X	—	#6 (7/32")	7/8"	Knifehead	1 lb	Bag	1
MA133M	X	—	#5-1/2 (7/32")	15/16"	Knifehead	1 lb	Bag	1
B91970	—	X	#5-1/2 (7/32")	15/16"	Knifehead	1 lb	Plastic Box	10
990829R91	X	—	#6 (7/32")	1"	Knifehead	1 lb	Bag	1
84341528	X	—	#5-1/2 (7/32")	1-1/8"	Knifehead	1 lb	Bag	1
B91971	—	X	#5-1/2 (7/32")	1-1/4"	Knifehead	1 lb	Plastic Box	10
990323R91	X	—	1/4"	3/4"	Knifehead	1 lb	Bag	1
990667R91	X	—	1/4"	7/8"	Knifehead	1 lb	Bag	1
990325R91	X	—	1/4"	1"	Knifehead	1 lb	Bag	1
B91974	—	X	#5-1/2 (7/32")	Assortment	9' sickle	assorted	Plastic Box	10

COUNTERSUNK RIVETS FOR RIVETED ASSEMBLIES WITH KNIFEBACK ON TOP OF SECTION



CASE IH PART NO.	DEPOT	DIRECT SHIP	DIAMETER	LENGTH	RIVET APPLICATION	PACKAGE QUANTITY	PACKAGE TYPE	ORDER MULTIPLE
185956C1	X	—	#5-1/2 (7/32")	5/8"	XHVY Section	100 pcs.	Bag	1
185957C1	X	—	#5-1/2 (7/32")	7/8"	Knifehead	48 pcs.	Bag	1

PAN HEAD RIVETS USED IN KNIFEHEADS ON RIVETED ASSEMBLIES FOR 1190, 1290, 1490 & 1590 PLATFORMS



CASE IH PART NO.	DEPOT	DIRECT SHIP	DIAMETER	LENGTH	RIVET APPLICATION	PACKAGE QUANTITY	PACKAGE TYPE	ORDER MULTIPLE
990667R91	X	—	1/4"	7/8"	Knifehead	1 lb	Bag	1
990325R91	X	—	1/4"	1"	Knifehead	1 lb	Bag	1
45-418	X	—	1/4"	1-1/8"	Knifehead	50 pcs.	Bag	1
990323R91	X	—	1/4"	3/4"	Knifehead	1 lb	Bag	1
104087	X	—	1/4"	1-1/4"	Knifehead	5 pcs.	Bag	1

OVAL HEAD BOLTS FOR STANDARD BOLTED KNIFE ASSEMBLIES



CASE IH PART NO.	LOCKNUTS INCLUDED IN KIT	DEPOT	DIRECT SHIP	DIAMETER	LENGTH	BOLT APPLICATION	PACKAGE QUANTITY	PACKAGE TYPE
86507777	Yes	X	X	12/24 (7/32")	5/8"	Sections	50	Plastic Box
86517390	Yes	X	X	12/24 (7/32")	3/4"	Knifehead	25	Plastic Box
86507778	Yes	X	X	12/24 (7/32")	7/8"	Knifehead	25	Plastic Box
86507779	Yes	X	X	12/24 (7/32")	1"	Knifehead	25	Plastic Box
86507780	Yes	X	X	12/24 (7/32")	1-1/8"	Knifehead	25	Plastic Box
1979166C1	No	X	—	12/24 (7/32")	1-1/8"	Knifehead	50	Box
700706479	Yes	X	—	12/24 (7/32")	1-1/4"	Knifehead	25	Plastic Box
	Yes	—	X	12/24 (7/32")	1-1/4"	Knifehead	25	Plastic Box
86586408	Yes	X	X	12/24 (7/32")	5/8", 7/8", 1"	Sickle Assortment	70, 3, 11	Plastic Box
84389557	Yes	—	X	12/24 (7/32")	5/8", 1", 1-1/4"	Sickle Assortment	50, 5, 5	Plastic Box
B91978	Yes	—	X	12/24 (7/32")	1", 1-1/4"	Knifehead Assortment	15,10	Plastic Box
323269A1	No	X	—	12/24 (7/32")	3/4"	Section Reinforcing Straps	50	Plastic Box
B92259	Yes	—	X	1/4"	1-1/4"	Knifehead	25	Plastic Box
87015068	Yes	X	—	12/24 (7/32")	9/16"	Sections	50	Plastic Box
86562960	YES	X	X	12/24 (7/32")	7/8", 1", 1-1/8"	Knifehead	9, 11, 5	Plastic Box

60° COUNTERSUNK BOLTS FOR KNIFE ASSEMBLIES WITH KNIFEBACK ON TOP OF SECTIONS, OR WITH COUNTERSUNK SECTIONS



CASE IH PART NO.	LOCKNUTS INCLUDED IN KIT	DEPOT	DIRECT SHIP	DIAMETER	LENGTH	BOLT APPLICATION	PACKAGE QUANTITY	PACKAGE TYPE
700715160	Yes	X	X	12/24 (7/32")	1/2"	Overlap Sections	25	Plastic Box
KX904529DS	Yes	—	X	12/24 (7/32")	9/16"	REG & HVY Sections	50	Plastic Box
84389558	Yes	—	X	12/24 (7/32")	5/8"	XHVY Sections	50	Plastic Box
227457A1	No	X	—	12/24 (7/32")	13/16"	Splice Kit & Reinforcement Kit	20	Bag
KX904528DS	Yes	—	X	12/24 (7/32")	1"	Knifehead	25	Plastic Box
227456A1	No	X	—	12/24 (7/32")	1-1/4"	Knifehead & Reinforcement Kit	20	Bag
84389559	Yes	—	X	12/24 (7/32")	1-1/4"	Knifehead	25	Plastic Box

HARDWARE/REPLACEMENT PARTS

BOLTS

82° COUNTERSUNK BOLTS TWIN SICKLE BOLTED ASSEMBLIES

CASE IH PART NO.	LOCKNUTS INCLUDED IN KIT	DEPOT	DIRECT SHIP	DIAMETER	LENGTH	BOLT APPLICATION	PACKAGE QUANTITY	PACKAGE TYPE	ORDER MULTIPLE
86512289	YES	X	X	12/24 (7/32")	1/2"	Overlap Sections	25	Plastic Box	1

OVAL SHOULDER BOLTS FOR CASE IH 1010 & 1020 1-1/2" CUT PLATFORMS



CASE IH PART NO.	LOCKNUTS INCLUDED IN KIT	DEPOT	DIRECT SHIP	DIAMETER	LENGTH	BOLT APPLICATION	PACKAGE QUANTITY	PACKAGE TYPE
1970505C1	NO	X	—	12/24 (7/32")	17/32"	Sections	100	Plastic Box
B91981	YES	—	X	12/24 (7/32")	17/32"	Sections	50	Plastic Box
B91982	YES	—	X	12/24 (7/32")	1-1/8"	Knifehead	25	Plastic Box

LOCK NUTS AND JAM NUTS FOR BOLTED KNIFE ASSEMBLIES



CASE IH PART NO.	DEPOT	DIRECT SHIP	DIAMETER	NUT APPLICATION	PACKAGE QUANTITY	PACKAGE TYPE	ORDER MULTIPLE
848083	X	—	12/24 (7/32")	All Other Applications	50	Bag	1



TOOLS & REPLACEMENT PARTS

WEARPLATES FOR CASE IH AND UNIVERSAL APPLICATIONS



CASE IH PART NO.	DEPOT	DIRECT SHIP	DIAMETER	PACKAGE QUANTITY	PACKAGE TYPE	ORDER MULTIPLE
B92854	—	X	5-1/2" with heat treated edge	50	Box	50

The "B" numbered wearplates are universal for most hay or combine platforms.

KNIFEHEAD PIN REPLACEMENT KIT FOR CASE IH BALANCED HEAD MOWERS



CASE IH PART NO.	DEPOT	DIRECT SHIP	DESCRIPTION	KIT CONTENTS	PACKAGE QUANTITY	ORDER MULTIPLE
B92479	—	X	Repair Kit for Knifehead 1-458971R1 Bushing 1-544553R1 Washer 1-458972R1 Plug	1-458973R4 Knifehead Pin	1	1

GENUINE PARTS STORE



www.partstore.caseih.com

Google Play™
for Android™



Apple® Store
for iPhone®





SHAPES CHARTS

59 SICKLE SECTIONS

60 – 61 HAY EQUIPMENT SHAPES CHARTS

62 COMBINE EQUIPMENT SHAPES CHARTS

SICKLE SECTIONS

TYPE OF SECTION

XHVY TS PL CTSK

FASTENER

CSKT COUNTERSUNK TOP
CSKB COUNTERSUNK BOTTOM

SECTION FINISH

PL Plated Section
BL Black Section

TYPE OF SECTION

SM Smooth
US Under Serrated
TS Top Serrated
SS Sta-Sharp
SSS Super-Sta-Sharp

SECTION THICKNESS

REG Regular 14 Gauge (.075/.090)
HVY Heavy 12 Gauge (.095/.110)
XHVY Extra Heavy 11 Gauge (.106/.121)

For order numbers with P/B/H suffix:

Order P suffix for merchandise pack of 10
Order B suffix for merchandise pack of 25
Order H suffix for merchandise pack of 100

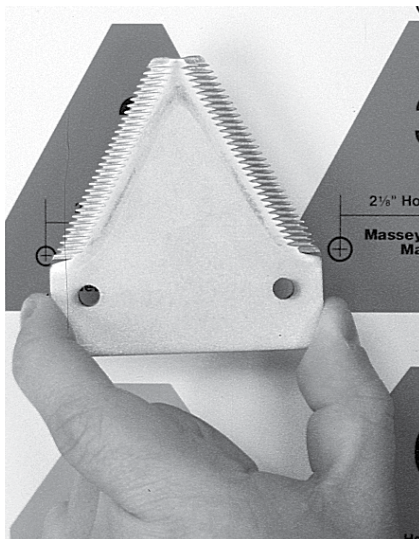

**SECTIONS ARE ACTUAL SIZE.
MATCH YOUR SECTION TO
APPROPRIATE SHAPE.**

HAY EQUIPMENT SHAPES CHARTS

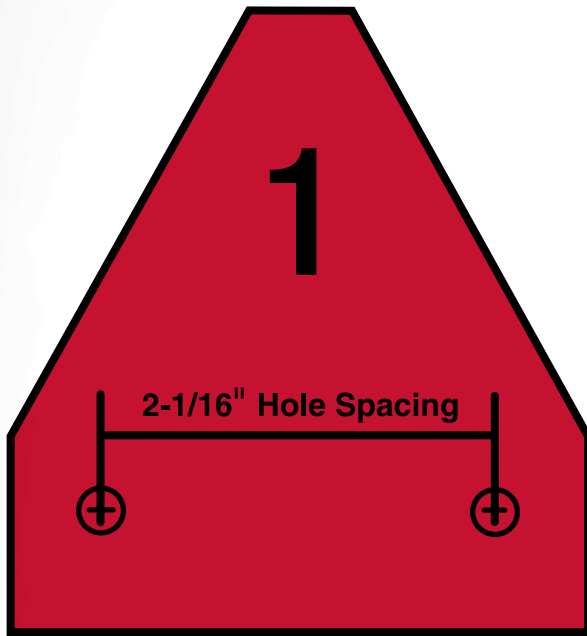

SHAPE #1

ORDER NUMBER	REPLACEMENT FOR		TYPE OF SECTION
049262	CASE IH		HVY-SM-PL
84416820	CASE IH HESSTON	049254	HVY-TS-PL
457607R3	CASE IH		XHVY-US-PL
112074P/H/A1	CASE IH HESSTON	112074A1 700705299BT	XHVY-SS-BL-3-HOLES
700705300/H	HESSTON N-H N-I	700705300 86616527 502933	XHVY-TS-PL
191256A1	CASE IH	191256A1	XHVY-SS-PL-3-HOLES
86615988/P	CASE IH		XHVY-TS-BL
86616588	CASE IH		XHVY-SSS-BL
86616691/P	CASE IH		XHVY-SS-BL
86616527/P	CASE IH		XHVY-TS-PL
700705300			XHVY-TS-PL
826720C3			XHVY-TS-BL
826722C2			XHVY-US-BL
84416820			HVY-TS-PL
604800			REG-US-PL
67630			REG-US-BL
826724C2			HVY-SM-BL
604810			REG-SM-PL

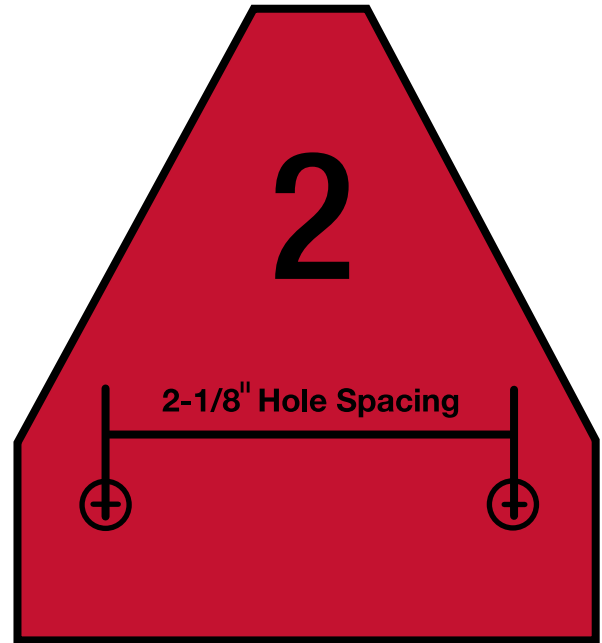

SHAPE #2

ORDER NUMBER	REPLACEMENT FOR		TYPE OF SECTION
275522	M-F N-H MACDON W-F	1046776M1 275522 22268 31-7970650	REG-TS-PL
KX211411DS	MACDON M-F	1327448C1 1071707M1	XHVY-TS-BL
345890A1	MACDON M-F	345890A1 1071707M1ST	XHVY-SSS-BL

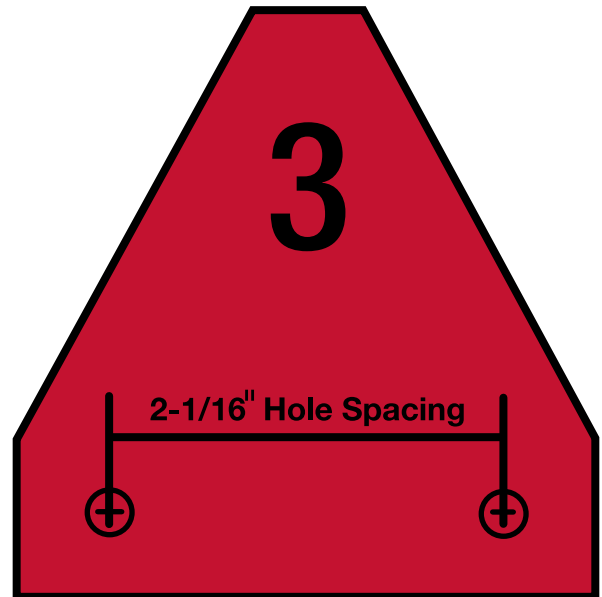

SHAPE #3

ORDER NUMBER	REPLACEMENT FOR		TYPE OF SECTION
86015164 KX211053DS	VERSATILE	SW1616CR	REG-TS-PL-CSKB REG-TS-BL-CSKB

HAY EQUIPMENT SHAPES CHARTS

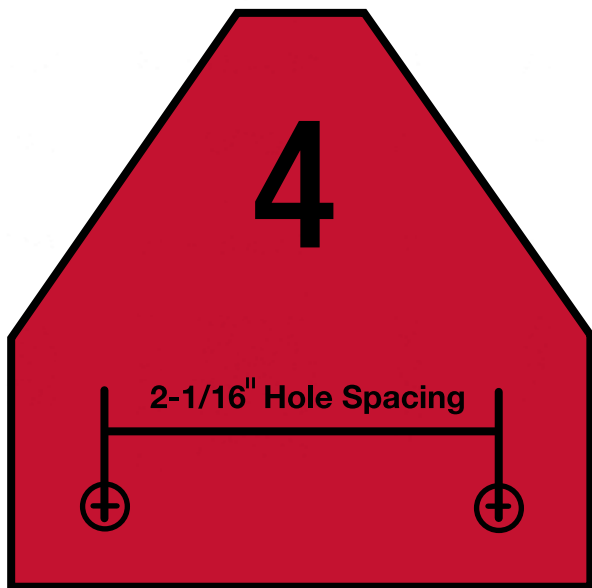

SHAPE #4

ORDER NUMBER	REPLACEMENT FOR		TYPE OF SECTION
84416053	VERSATILE	V1776	XHVV-TS-BL

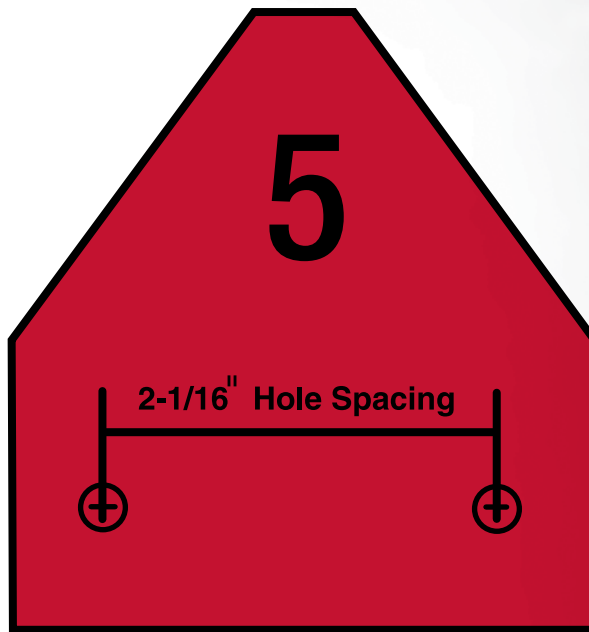

SHAPE #5

ORDER NUMBER	REPLACEMENT FOR		TYPE OF SECTION
436995A1	GEHL	340-32041	XHVV-TS-BL

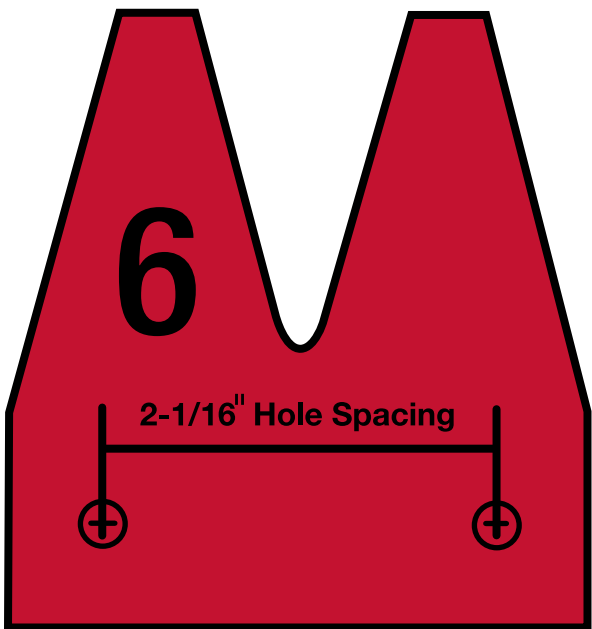

SHAPE #6

ORDER NUMBER	REPLACEMENT FOR		TYPE OF SECTION	HOLES
B93329P/H/B	CASE IH	1970390C4	XHVV-SS-BL	3 OVAL
B93330B	CASE IH	191257A1	XHVV-SS-PL	3 OVAL
1970390C4	HERSCHEL	TJ7000	XHVV-TS-BL	3 OVAL

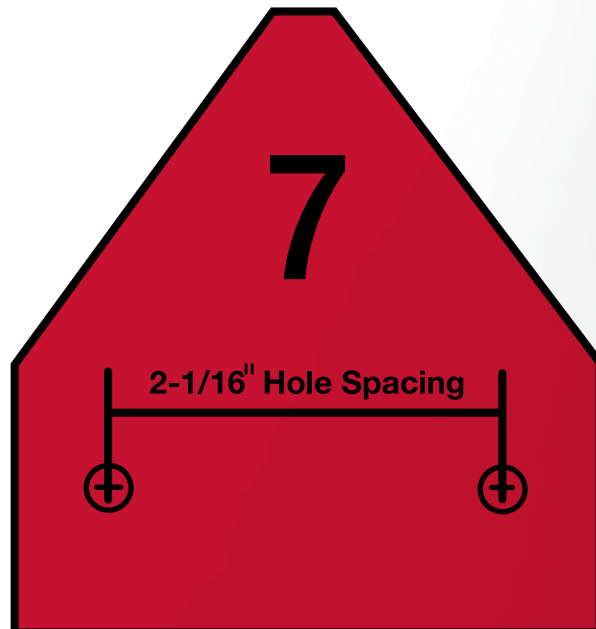

SHAPE #7

ORDER NUMBER	REPLACEMENT FOR		TYPE OF SECTION
134104	JD	H130478/H125893	XHVV-TS-BL

DISC MOWER KNIVES

MOWER-CONDITIONERS

HAY MACHINES

WINDROWERS

COMBINES

HARDWARE/PARTS

SHAPES CHARTS

COMBINE EQUIPMENT SHAPES CHARTS

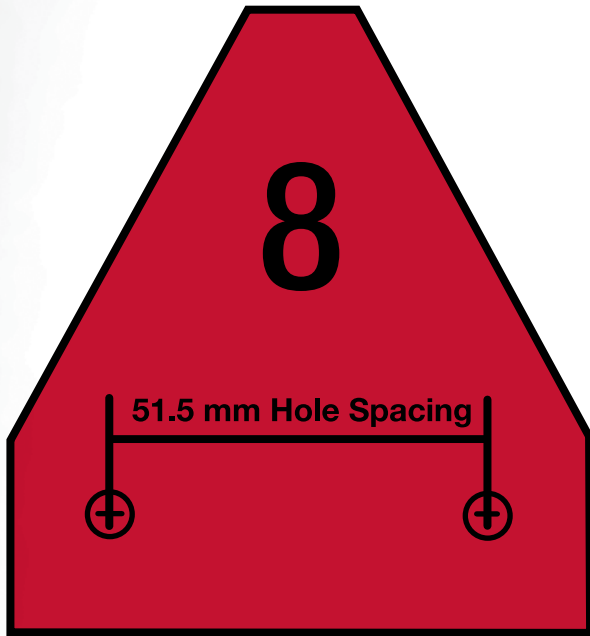

SHAPE #8

ORDER NUMBER	REPLACEMENT FOR		TYPE OF SECTION
B95013P	SCH	420-100-047	HVY-TS-BL M6X16

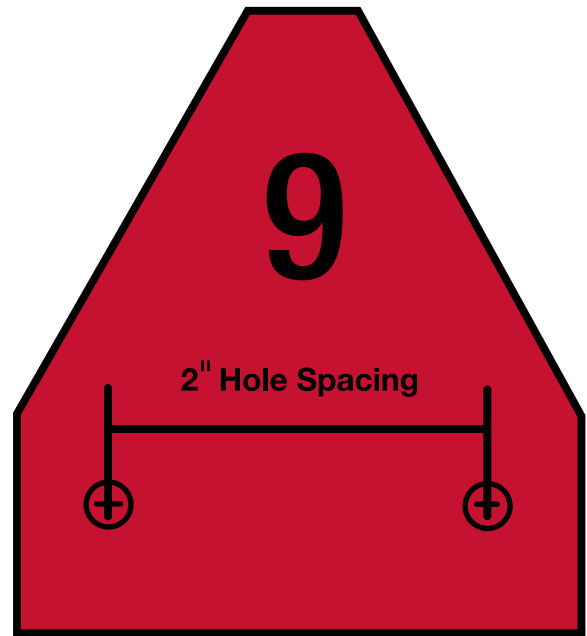

SHAPE #12

ORDER NUMBER	REPLACEMENT FOR		TYPE OF SECTION
V93545/PDS	VERSATILE V93545		R TS BL

My Shed™ Mobile App 2.1

MANAGE YOUR EQUIPMENT
FROM YOUR SMARTPHONE.

SEE PAGE 2 FOR DETAILS.



Google Play™
for Android™



Apple® Store
for iPhone®



22268.....	25, 60	848094.....	42	84177687.....	11	84585657.....	41	86616530.....	24
46436.....	44, 45	853638.....	11	84177688.....	11	84585659.....	41	86616531.....	24
48868.....	28, 49	853639.....	11	84223452.....	39	84585660.....	41	86616532.....	23
49254.....	25	853819.....	11, 12	84242662.....	39	84585661.....	41	86616533.....	23
049254.....	60	6497119.....	38	84255699.....	11	84585662.....	41	86616534.....	23, 24
49262.....	26	6566178.....	21	84255700.....	11	84585663.....	41	86616535.....	23, 24
049262.....	60	6616591.....	23	84271203.....	8, 11	86015164.....	25, 60	86616536.....	23
64691.....	16	6821078.....	17, 35	84271205.....	8, 11	86507777.....	15, 16, 17, 18, 19, 20, 31, 32, 34, 35, 36, 37, 38, 42, 44, 45, 46, 53, 55	86616537.....	23
67630.....	18, 26, 60	6832703.....	37, 52	84275285.....	41	86507779.....	16, 18, 32, 34, 36, 37, 55	86616538.....	24
76417.....	23, 24	9847683.....	8, 11	84314629.....	39	86507780.....	55	86616539.....	24
104087.....	54	9847684.....	8, 11	84314630.....	39	86507781.....	31	86616540.....	24
111724.....	12	47601016.....	41	84341528.....	54	86511990.....	18	86616541.....	24
111725.....	12	47601017.....	41	84343225.....	8, 11	86512289.....	42, 56	86616542.....	23
113268.....	12	47601019.....	41	84343226.....	8, 11	86517390.....	15, 17, 20, 32, 35, 36, 42, 55	86616543.....	23
113269.....	12	47601020.....	41	84375859.....	11	86532078.....	8, 11	86616544.....	23
00117849.....	36	47601021.....	41	84389548.....	15, 16, 18, 31, 32, 34, 45, 53	86561092.....	12	86616545.....	23
125446.....	12	47601022.....	41	84389553.....	53	86561093.....	12	86616546.....	27
125447.....	12	47601023.....	41	84389554.....	15, 16, 18, 32, 34, 44, 45, 53	86561684.....	39	86616560.....	27
134104.....	61	47601024.....	41	84389555.....	54	86561686.....	39	86616588.....	23, 24, 26, 60
00134757.....	36	47601025.....	41	84389557.....	55	86561692.....	39	86616589.....	27
137636.....	35	47601026.....	41	84389558.....	55	86561692.....	39	86616590.....	27
142984.....	17, 52	47601027.....	41	84389559.....	55	86562960.....	55	86616591.....	23, 24, 26
274096.....	11, 12	47601029.....	41	84399893.....	46, 52	86563534.....	39	86616592.....	27
274097.....	11, 12	47601030.....	41	84416053.....	25, 61	86577390.....	20	86616593.....	27
274230.....	11, 12	47601031.....	41	84416820.....	25, 26, 32, 34, 37, 38, 60	86586408.....	55	86616601.....	24
275522.....	25, 60	47601032.....	41	84425930.....	11	86615985.....	24, 27	86616602.....	24
451948.....	15	47601034.....	41	84425931.....	11	86615986.....	27	86616603.....	24
478640.....	12	47601038.....	41	84429100.....	41, 49	86615987.....	27	86616604.....	24
478641.....	12	47601040.....	41	84429101.....	41, 49	86615988.....	21, 23, 24, 25, 26, 38, 60	86616605.....	23
478649.....	12	47601041.....	41	84429102.....	41, 49	86616055.....	24	86616606.....	23
478650.....	12	47601042.....	41	84429102.....	41, 49	86616056.....	24	86616607.....	23
502933.....	25, 60	47601043.....	41	84467282.....	41, 49	86616057.....	23	86616608.....	23
526215.....	12	47601044.....	41	84467292.....	41, 49	86616058.....	23	86616610.....	24
526216.....	12	51200279.....	20, 27, 35, 36, 37	84476750.....	39	86616059.....	23	86616611.....	24
604658.....	12	51200281.....	20, 27, 35, 36, 37	84476751.....	39	86616060.....	23	86616612.....	24
604659.....	12	51200830.....	36	84476752.....	39	86616061.....	23	86616613.....	24
604800.....	32, 60	55903210.....	12	84476752.....	39	86616062.....	23	86616614.....	23
604810.....	26, 60	56150000.....	12	84476754.....	39	86616072.....	24	86616615.....	23
612634.....	12	56151200.....	12	84543491.....	41	86616073.....	24	86616616.....	23
612635.....	12	56151210.....	12	84585643.....	41	86616074.....	23	86616617.....	23
612737.....	12	56151300.....	12	84585644.....	41	86616075.....	23	86616618.....	24
612738.....	12	56151310.....	12	84585645.....	41	86616076.....	23	86616619.....	24
706226.....	25	56451200.....	12	84585646.....	41	86616077.....	23	86616620.....	24
748145.....	28, 49	56451300.....	12	84585647.....	41, 51	86616527.....	23, 24, 25, 26, 60	86616621.....	24
748210.....	20	70071325.....	17	84585648.....	41	86616528.....	27	86616622.....	23
766726.....	11, 12	70071560.....	36	84585649.....	41	86616529.....	27	86616623.....	23
766727.....	11, 12	73342915.....	49	84585650.....	41			86616624.....	23
784220.....	11, 12	73342916.....	49	84585651.....	41			86616625.....	23
784221.....	11, 12	73342917.....	49	84585652.....	41			86616626.....	24
785608.....	11	73342918.....	49	84585653.....	41			86616627.....	24
785609.....	11	80289488.....	21	84585654.....	41			86616628.....	24
848083.....	15, 16, 17, 18, 19, 20, 31, 32, 34, 35, 36, 37, 38, 42, 44, 45, 46, 47, 53, 56	84158453.....	39	84585655.....	41			86616629.....	24
		84158454.....	39	84585656.....	41			86616630.....	23
		84158455.....	39					86616631.....	23

INDEX

86616632. 23	86624469. 21	87298472. 10	700134757. 19, 20, 35,	4120114740. 12
86616633. 23	86624751. 12	87298584. 9	36, 37, 52	1 – 8651199. 15
86616634. 27	86624752. 12	87298585. 9	700134758. 20, 36, 52	101001A2. 44, 52
86616635. 27	86625665. 11, 12	87298586. 9	700148847. 37, 52	101987C95. 16
86616689. 23, 24, 26	86625666. 11, 12	87298587. 9	700705300. 15, 16, 17, 19,	101988C95. 16
86616691. 23, 24, 26, 42, 60	86625667. 11, 12	87298588. 9	20, 25, 26, 31, 32,	1036362M1. 25
86616692. 27, 42	86625668. 11, 12	87298589. 9	34, 35, 36, 60	1046776M1. 25, 60
86616693. 27, 42	86625669. 11, 12	87298590. 9	700705462. 28, 49	1071707M1. 25, 60
86616694. 27	86625670. 11, 12	87298591. 9	700705463. 28, 49	1071707M1ST. 60
86616695. 27	86625671. 11, 12	87298592. 9	700706479. 17, 19, 20, 31,	112074A1. 18, 26, 42, 43,
86616696. 24	86625672. 11, 12	87298593. 9	34, 35, 37, 55	48, 53, 60
86616697. 24	86625673. 11, 12	87298594. 9	700709577. 35	112074H. 26, 48, 60
86616698. 24	86625674. 12	87298595. 9	700709578. 35	112074P. 26, 48, 60
86616699. 24	86626704. 12	87298596. 9	700709579. 35	112428A1. 52
86616700. 23	86626705. 12	87298597. 9	700709580. 35	1133939R1. 12
86616701. 23	86626706. 12	87298598. 9	700709583. 17	1133940R1. 12
86616702. 23	86626707. 12	87298599. 9	700709588. 17	126622A2. 46
86616703. 23	86626708. 12	87298600. 9	700709622. 19, 35	126689A1. 46
86616704. 24	86630786. 38, 42	87298601. 9	700709623. 19, 35	126749A1. 48
86616705. 24	86630787. 42	87298602. 9	700709888. 34	1281291C92. 18
86616706. 24	86837561. 11, 12	87298603. 9	700709889. 34	1281481C92. 32
86616707. 24	86900832. 42	87298604. 9	700709895. 34	1307280C3. 15, 16, 42, 44, 52
86616708. 23	86900833. 42	87298605. 9	700709896. 34	1308217C92. 45
86616709. 23	86900834. 42	87298606. 9	700709897. 34	1313795C95. 44
86616710. 23	86900835. 42	87348084. 11	700710967. 34	131482A1. 46
86616711. 23	86977981. 42	87348087. 11	700711767. 17	1316030C2. 28, 49
86616712. 24	86977982. 42	87422088. 46	700711857. 12	1316161C95. 42
86616713. 24	87015068. 55	87422089. 46	700711858. 12	1319392C2. 28, 49
86616714. 24	87029587. 8, 11, 12	87456669. 46	700712775. 17	1327411C1. 46
86616715. 24	87029588. 8, 11, 12	87456670. 46	700712888. 12	1327448C1. 25, 46, 60
86616716. 23	87037027. 12	87457982. 46	700712889. 12	1650 3363. 12
86616717. 23	87037117. 39	87470018. 41, 49	700713251. 17	1650 7793. 12
86616718. 23	87056009. 38	87470186. 41, 49	700713983. 12	1650 7794. 12
86616719. 23	87056010. 38	87470187. 41, 49	700713984. 12	176696C93. 45
86616720. 24	87056011. 38	87470188. 41	700715160. 20, 36, 55	176697C93. 45
86616721. 24	87056012. 38	87580643. 33	700715165. 20, 36	176721C93. 45
86616722. 24	87056013. 38	87602273. 33	700715166. 20, 36	176722C1. 45, 52
86616723. 24	87056014. 38	87663841. 41, 49	700715167. 20, 36	178466C91. 45
86616724. 23	87056015. 38	87670866. 39	700715168. 20, 36	179736C3. 48
86616725. 23	87056016. 38	87728899. 41, 49	700715170. 36	179757C1. 52
86616726. 23	87056017. 38	87728905. 41, 49	700715575. 12	180480C1. 52
86616727. 23	87056018. 38	88625674. 11	700715576. 12	185956C1. 54
86616728. 27	87298449. 9	90258699. 12	700715778. 36	185957C1. 54
86616729. 27	87298450. 9	90258700. 12	700715779. 36	187418C93. 45
86616976. 28	87298451. 9	90261559. 12	700715808. 37	191256A1. 20, 26, 36, 43, 60
86617121. 28	87298452. 9	90261560. 12	700715809. 37	191257A1. 61
86617752. 23, 24	87298453. 9	700109725. 17, 19, 20,	700715810. 37	1958203C1. 18
86617755. 23, 24	87298466. 10	35, 36, 52	700715811. 37	1958205C1. 18
86617759. 23, 24, 28, 49	87298467. 10	700111003. 17, 19, 35, 37	700715814. 37	1958207C1. 18
86617760. 21, 23, 24,	87298468. 10	700111204. 17, 34, 37, 52	700715815. 37	1960310C1. 16
28, 49	87298469. 10	700114594. 20, 36	700715816. 37	1970390C4. 44, 48, 61
86621872. 8, 11, 12	87298470. 10	700116709. 37	700715817. 37	1970400C6. 44
86621873. 8, 11, 12	87298471. 10	700118673. 17	4120114730. 12	1970402C5. 44

1970404C5..... 44	381137A1..... 46	700705300P..... 25, 26	B92389..... 27	KX904529DS..... 55
1970442C5..... 44	394618A1..... 44, 48	823711C3..... 16, 26, 32	B92393..... 53	MA133M..... 16, 18, 32, 54
1970502C5..... 44	395823A1..... 46	823713C3..... 16, 26, 31, 32,	B92401..... 25	MA812..... 18, 52
1970503C5..... 44	398746A1..... 44	34, 44	B92402..... 25	MA999..... 18
1970504C6..... 44	398747A2..... 44	824594C91..... 16, 32, 34	B92458..... 21	SW1616CR..... 25, 60
1970505C1..... 44, 56	398748A2..... 44	824639C1..... 31	B92479..... 57	SW1776CR..... 25
1970506C1..... 44	398749A2..... 44	824981C1..... 32, 52	B92537..... 32	TJ7000..... 61
1970507C2..... 44	398750A2..... 44	826720C3..... 18, 25, 26, 44,	B92539..... 32, 38	V1776..... 61
197183C93..... 45	398751A2..... 44	48, 60	B92854..... 57	V93545..... 62
197230C91..... 44, 45	398752A2..... 44	826722C2..... 15, 18, 26, 60	B92973..... 51	V93545/PDS..... 62
197462C93..... 44	420-100-047..... 25, 47, 62	826722PC2..... 25	B92983..... 44	W501017E..... 25
197463C93..... 44	436995A1..... 42, 43, 48, 61	826724C2..... 18, 26, 60	B93244..... 44	ZA290658..... 28, 49
197464C93..... 44	45-418..... 16, 32, 54	827721C92..... 32	B93329B..... 44, 48, 61	ZA502562..... 16
197465C93..... 44	451828A3..... 42	827813C92..... 32	B93329H..... 48, 61	ZA502643..... 28, 49
197466C93..... 44	451829A3..... 42	827814C92..... 32	B93329P..... 48, 61	ZA526215..... 12
1979166C1..... 17, 19, 31, 35,	451830A2..... 42, 43	86507778-17..... 32	B93330B..... 48, 61	ZA526216..... 12
42, 46, 55	451831A2..... 42, 43	86512289-6..... 42	B93330P..... 48	ZA527330..... 11
1979166C1-1..... 42	451832A2..... 42, 43	86615988P..... 26, 60	B93356..... 31, 53	ZA527331..... 11
1980897C1..... 54	451833A2..... 42, 43	86616527P..... 26, 60	B93638..... 44	ZAK101988..... 16
227213A1..... 47	451834A3..... 43	86616689P..... 26	B93640..... 44	ZAK101988T..... 16
227455A1..... 47	451835A3..... 43	86616691P..... 26, 60	B95005..... 53	ZAK128129..... 18
227456A1..... 47, 55	451839A2..... 43	86616976..... 49	B95013P..... 25, 47, 62	ZAK1281291..... 18
227457A1..... 47, 55	457604R3..... 26	87027493-3..... 42	B95021..... 20, 36	ZAK1308217..... 45
31-7970650..... 60	457605R3..... 26	87423458-74..... 42	B95022..... 20, 36	ZAK1337024..... 31
321848A1..... 41, 51	457606R3..... 26	87439540E..... 42	B95023..... 20, 36	ZAK176720..... 45
321849A2..... 51	457607R3..... 16, 18, 25,	87439541E..... 42	B95024..... 20, 36	ZAK1958203..... 18
323269A1..... 55	32, 60	87439542E..... 42	B95027..... 20, 36	ZAK1958207..... 18
324070A1..... 28, 49	458968R93..... 18	87439543E..... 42	B95028..... 20, 36	ZAK197463..... 44
340-32041..... 61	458971R1..... 57	87439544E..... 42	B95034..... 18	ZAK197466..... 44
345890A1..... 25, 46, 60	458972R1..... 57	9-65474..... 15	B96615..... 43	ZAK462380..... 18
371613A2..... 43	458973R4..... 57	990323R91..... 54	B96616..... 43	ZAK462381..... 18
371617A2..... 43	462380R93..... 18	990325R91..... 16	CC19332..... 12	ZAK463159..... 18
371618A2..... 43	462381R93..... 18	990325R91..... 32, 54	CC19333..... 12	ZAK463159T..... 18
371619A2..... 43	463159R93..... 18	990667R91..... 54	CC20500..... 12	ZAK463294..... 18
371620A2..... 43	463182R93..... 18	990719R91..... 44, 54	CC20501..... 12	ZAK502930..... 16
371621A3..... 43	463408R93..... 18	990817R91..... 54	CC21780..... 12	ZAK502931..... 16
371622A3..... 43	467749R92..... 18	990829R91..... 54	CC21781..... 12	ZAK540605..... 15
371632A1..... 43	540605R92..... 15	B91608..... 32	CC26780..... 12	ZAK540605T..... 15
371636A1..... 43	540607R1..... 15	B91609..... 32	CC26781..... 12	ZAK7709622..... 19
371638A2..... 43	542816R92..... 15	B91610..... 31	CC44004..... 12	ZAK7709623..... 35
371642A3..... 43	544553R1..... 57	B91963..... 44, 45, 53	CC44005..... 12	ZAK7709623C..... 19
371643A1..... 43	559269R2..... 28, 49	B91969..... 15, 16, 18, 32, 54	CC44006..... 12	ZAK80648..... 31
371644A2..... 43	56692C91..... 18	B91970..... 44, 54	CC44007..... 12	ZAK80650..... 31
371646A1..... 43	595648R1..... 52	B91970-17..... 32	DM155..... 12	ZAK827701..... 34
371647A1..... 43	611759R1..... 15, 16, 18,	B91971..... 54	DM160..... 12	ZAK827724T..... 34
371649A1..... 43	44, 52	B91974..... 54	E80206..... 12	ZAK827813..... 32
371650A1..... 43	613842R2..... 32, 52	B91978..... 55	E80208..... 12	ZAK827813T..... 32
371652A1..... 43	634788R3..... 45, 48	B91981..... 56	H125893..... 61	ZAK827814..... 32
371658A1..... 43, 51	634793R3..... 45, 48	B91982..... 56	H130478..... 61	ZAK827815T..... 32
37302223M1..... 12	634794R3..... 45, 48	B92229..... 15, 21	KX211053DS..... 60	ZAK827816..... 32
37302224M1..... 12	683937M1..... 25	B92259..... 16, 32, 34, 55	KX211411DS..... 60	ZAK827830T..... 32
37302225M1..... 12	700705299BT..... 60	B92387..... 28, 49	KX211411PDS..... 25	ZAK831607..... 32
37302226M1..... 12	700705300H..... 26, 60	B92388..... 28, 49	KX904528DS..... 55	



**For more information, please contact your
Case IH dealer or visit partstore.caseih.com.**

Safety never hurts![™] Always read the Operator's Manual before operating any equipment. Inspect equipment before using it, and be sure it is operating properly. Follow the product safety signs, and use any safety features provided.

Specifications, descriptions and illustrative material herein are as accurate as known at time of publication, but are subject to changes without notice. Availability of some models and equipment builds varies according to the country in which the equipment is used.

CNH Industrial America LLC reserves the right to make improvements in design and changes in specification at any time without notice and without incurring any obligation to install them on units previously sold.

PM-16524 08/2014 Replaces: PM-14458 and PM-13728

©2014 CNH Industrial America LLC. All rights reserved. Case IH is a trademark registered in the United States and many other countries, owned by or licensed to CNH Industrial N.V., its subsidiaries or affiliates. Any trademarks referred to herein, in association with goods and/or services of companies other than CNH Industrial America LLC, are the property of those respective companies. www.caseih.com